



**Clamp-on 110V
Transit Time Ultrasonic Heat Meter
Clamp-on & Insertion**

Operation & Maintenance

Manual

REV 2/2016

CONTENTS

PART-1 INTRODUCTION	1
1.1 GENERAL	1
1.2 PRINCIPLE OF MEASUREMENT	1
1.3 APPLICATIONS	2
1.4 FEATURES	3
1.5 SPECIFICATIONS	3
1.6 PARTS IDENTIFICATION	5
PART-2 TRANSDUCER INSTALLATION.....	6
2.1 GENERAL	6
2.2 MOUNTING LOCATION	6
2.3 TRANSDUCER SPACING.....	7
2.4 TRANSDUCER MOUNTING.....	9
2.5 TRANSDUCER MOUNTING INSPECTION AND COUPLANT APPLICATION	13
PART-3 TRANSMITTER INSTALLATION CONNECTION AND OPERATION INSTRUCTIONS	14
3.1 TRANSMITTER INSTALLATION	14
3.2 TRANSDUCER CONNECTIONS	15
3.3 TRANSMITTER POWER AND OUTPUT CONNECTIONS.....	16
3.4 KEYPAD CONFIGURATION.....	17
PART-4 WINDOWS DISPLAY EXPLANATIONS	22
PART-5 ENERGY FUNCTION	32
5.1 INTRODUCTION.....	32
5.2 WIRING CONNECTION.....	32
5.3 ENERGY CALCULATION	33
5.4 TEMPERATURE RANGE.....	33
PART-6 TEMPERATURE SENSOR INSTALLATION.....	34
6.1 PT1000 TEMPERATURE SENSOR.....	34
6.2 TEMPERATURE SENSOR INSTALATION	34
(a) 6.2.1 CLAMP-ON TEMPERATURE SENSOR.....	34
(b) 6.2.2 INSERTION TEMPERATURE SENSOR.....	34
PART-7 HOW TO USE MENU FUNCTIONS	36
5.1 HOW TO JUDGE WHETHER THE INSTRUMENT WORKS PROPERLY	36
5.2 HOW TO JUDGE THE LIQUID FLOWING DIRECTION	36
5.3 HOW TO RESET THE DEFAULT SETUPS	36
5.4 HOW TO STABILIZE THE FLOW	36
5.5 HOW TO USE THE ZERO-CUTOFF FUNCTION.....	37
5.6 HOW TO SETUP A ZERO POINT CALIBRATION	37
5.7 HOW TO USE SCALE FACTOR	37
5.8 HOW TO USE THE OPERATION LOCKER.....	38

5.9 HOW TO USE THE 4~20M A OUTPUT	38
5.10 HOW TO USE THE FLOW RATE FREQUENCY OUTPUT.....	38
5.11 HOW TO USE RELAY OUTPUT	39
5.12 HOW TO SET THE DATE AND TIMER.....	39
5.13 ON/OFF NET TOTALIZER.....	39
5.14 UNITS OPTIONS	39
5.15 LCD BACKLIT OPT IONS	39
5.16 USE MENU WINDOWS FOR TRANSDUCER MOUNTING INSPECTION	40
PART-8 TROUBLESHOOTING AND FAQ.....	42
6.1 TROUBLESHOOTING.....	42
6.2 FREQUENTLY ASKED QUESTIONS AND ANSWERS	44
PART-9 WARRANTY AND SERVICE.....	46
7.1 WARRANTY	46
7.2 SERVICE	46
APPENDIX 1 INSERTION TRANSDUCER INSTALLATION	47
A, MENU CONFIGURATION	47
B, INSTALLATION LOCATING.....	47
C, DRILLING HOLES	49
D, MOUNTING THE TRANSDUCERS	50
E, TRANSDUCER WIRING	51
F, HOW TO OBTAIN GOOD SIGNAL STRENGTH AND SIGNAL QUALITY.....	51
APPENDIX 2 TRANSDUCER GUIDE RAIL INSTALLATION.....	52
APPENDIX 3 FULLD CHARACTERISTIC (SOUND SPEED).....	56
1. FLUID PROPERTIES.....	56
2. WATER SOUND SPEED.....	58
3. PIPE MATERIAL SOUND SPEED TABLE.....	59
APPENDIX 4 CLAMP-ON 1100 COMMUNICATIONS PROTOCOL	60
1. OVERVIEW.....	60
2. SERIAL PORT DEFINITIONS	60
3. RS232 COMMUNICATION PROTOCOL AND THE USE	60
4. RS485 COMMUNICATION PROTOCOL AND THE USE	64
5. KEY CODE.....	67
APPENDIX 5 MODBUS-RTU COMMUNICATIONS PROTOCOL.....	69

PART-1 INTRODUCTION

1.1 GENERAL

It is the engineers and technicians' hope to measure the flow on the non-invasive pipeline reliably. Series CLAMP-ON 1100 are state-of-the-art universal transit-time ultrasonic flow meters, fit to measure flow of full pipe line, providing a measuring system with unsurpassed accuracy, versatility, ease of installation and dependability. Although designed primarily for cleaner liquids, the flow meter is tolerant of liquids with the small amount of air bubbles or suspended solids found in most industrial environments.

1.2 PRINCIPLE OF MEASUREMENT

The CLAMP-ON 1100 ultrasonic flow meter is designed to measure the fluid velocity of liquid within a closed pipe. The transducers are a non-invasive, clamp-on type, which will provide benefits of non-fouling operation and easy installation.

The CLAMP-ON 1100 transit time flow meter utilizes two transducers that function as both ultrasonic transmitters and receivers. The transducers are clamped on the outside of a closed pipe at a specific distance from each other. The transducers can be mounted in V-method where the sound transverses the pipe twice, or W-method where the sound transverses the pipe four times, or in Z-method where the transducers are mounted on opposite sides of the pipe and the sound crosses the pipe once. This selection of the mounting method depends on pipe and liquid characteristics. The flow meter operates by alternately transmitting and receiving a frequency modulated burst of sound energy between the two transducers and measuring the transit time that it takes for sound to travel between the two transducers. The difference between the transit-time is directly and exactly related to the velocity of the liquid in the pipe, as shown in Figure 1.

$$V_f = Kdt / TL$$

Where: V_f Liquid velocity
 K Constant
 dt Difference in time of flight
 TL Average Transit Time

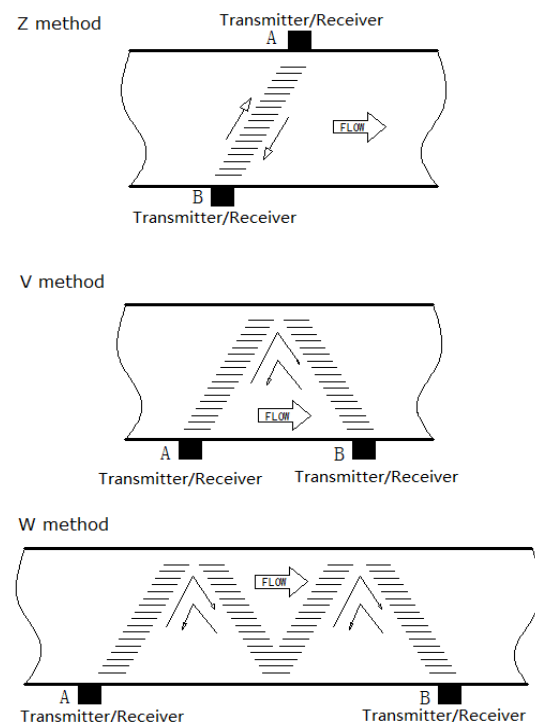

Figure 1

When measuring temperature, the two temperature sensors of Pt1000 clamp on the pipeline or insert in the pipe, and get two temperature values.

The value of energy is indicated / measured based on the following mathematical model:

$$Q = \int_{V_1}^{V_2} k(t_1 - t_2) dV$$

Where: Q – Quantity of heat given up

V – Volume of liquid passed

k – Heat coefficient, is a function of the properties of the heat-conveying liquid at the relevant temperatures and pressure

t1 – Inlet temperature of liquid

t2 – Outlet temperature of liquid

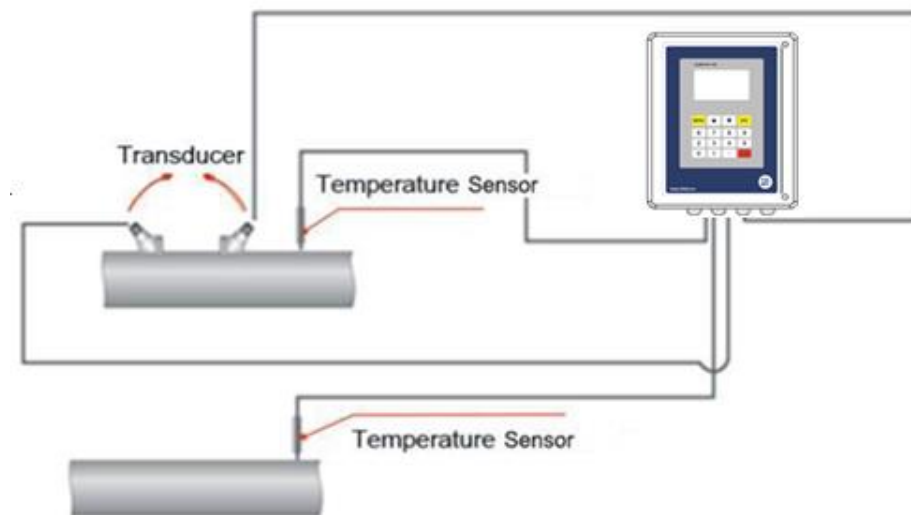

1.3 APPLICATIONS

1. Water, sewage (with low particle content) and sea water
2. Water supply and drainage water
3. Process liquids; Liquors
4. Milk, yoghurt milk
5. Gasoline kerosene diesel oil
6. Power plant
7. The flow patrolling and examining
8. Metallurgy, Laboratory
9. Energy-conservation, economize on water
10. Food and medicine

11 Heat measures, Heat balance

12 On-the-spot check-up, standard, the data are judged, Pipeline leak detection

1.4 FEATURES

- Advanced Digital Signal Processor technology and the MultiPulse™ transducer technology
- CLAMP-ON 1100V is Clamp-on type, non-invasive system allows solids to pass through the pipe within effect on meter. Y-strainers or filtering devices are not needed. Digital cross-correlation technology
- Since the sensors do not contact the liquid, fouling and maintenance are eliminated.
- Provides easy and low cost installation by clamping on the outside of existing piping systems.
- Clear, user-friendly menu selections make CLAMP-ON 1100 simple and convenient to use
- A pair of sensors can satisfy different materials , wide different pipe diameters
- 4 Lines display, can display total flow, flow rate, velocity and meter run status. Parallel operation of positive, negative and net flow totalizes with scale factor and 7 digit display, while the output of totalize pulse and frequency output are transmitted via open collector.
- U.S., British and Metric measurement units are available. Meanwhile, almost all-universal measurement units worldwide may be selected to meet customer's requirements.

1.5 SPECIFICATIONS

Specifications: Transmitter

Measurement principle	Ultrasonic transit-time difference correlation principle
Flow velocity range	0.01 to 12 m/s, bi-directional
Resolution	0.25mm/s
Repeatability	0.2% of reading
Accuracy	±1.0% of reading at rates >0.3 m/s);±0.003 m/s of reading at rates<0.3 m/s
Response time	0.5s
Sensitivity	0.003m/s

Damping of displayed value	0-99s(selectable by user)
Liquid Types Supported	Both clean and somewhat dirty liquids with turbidity <10000 ppm
Power Supply	AC: 85-265V DC: 24V/500mA
Enclosure type	Wall-mounted
Degree of protection	IP66 according to EN60529
Operating temperature	-20°C to +60°C
Housing material	Fiberglass
Measurement Channels	1
Display	4 line×16 English letters LCD graphic display, backlit
Units	User Configured (English and Metric)
Rate	Rate and Velocity Display
Totalized	gallons, ft ³ , barrels, lbs, liters, m ³ ,kg
Communication	4~20mA(accuracy 0.1%),OCT, Relay, RS232, RS485 (Modbus),Logged data
Security	Keypad lockout, system lockout
Size	244*196*144mm
Weight	2.4kg

Specifications:

Transducer (clamp-on)

Degree of protection	IP67 or IP68 according to EN60529
Suited Liquid Temperature	Std. Temp.: -35°C~85°C High Temp.: -35°C~150°C
Pipe diameter range	20-50mm for type S, 40-1000mm for type M, 1000-6000mm for type L
Transducer Size	Type S 52(h)*28(w)*26(d)mm Type M 60(h)*34(w)*33(d)mm Type L 80(h)*40(w)*42(d)mm
Material of transducer	Aluminum for standard temp. sensor, and peek for high temp. sensor
Cable Length	Std: 10m
Temperature Sensor	Pt1000, 0 to 200°C, Clamp-on and Insertion type Accuracy: ±0.1%

Transducer (Insertion)

Degree of protection	IP65. IP67 or IP68 according to EN60529
Suited Liquid Temperature	Std. Temp.: -35°C~85°C for short periods up to 100°C High Temp.: -35°C~150°C for short periods up to 180°C
Pipe diameter range	S type for DN65-6000mm
Transducer Size	58*58*295mm
Material of transducer	Stainless steel
Cable Length	Std: 10m

1.6 PARTS IDENTIFICATION



Transmitter



Mounting rail



Clamp-on transducer



Insertion transducer



S-S Belt



Couplant



PT1000 clamp-on



PT1000 insertion

PART-2 TRANSDUCER INSTALLATION

2.1 GENERAL

The transducers that are utilized by the Series CLAMP-ON 1100 contain piezoelectric crystals for transmitting and receiving ultrasound signals through walls of liquid piping systems. The transducers are relatively simple and straight-forward to install, but spacing and alignment of the transducers is critical to the system's accuracy and performance. Extra care should be taken to ensure that these instructions are carefully executed.

Mounting of the clamp-on ultrasonic transit time transducers is comprised of three steps:

Selection of the optimum location on a piping system.

Entering the necessary parameters into the CLAMP-ON 1100 keypad.

(CLAMP-ON 1100 will calculate proper transducer spacing based on these entries (menu 25))

Pipe preparation and transducer mounting.

2.2 MOUNTING LOCATION

The first step in the installation process is the selection of an optimum location for the flow measurement to be made. For this to be done effectively, a basic knowledge of the piping system and its plumbing is required.

An optimum location is defined as:

A piping system that is completely full of liquid when measurements are being taken.

The pipe may become completely empty during a process cycle - which will result in an error code being displayed on the flow meter while the pipe is empty. Error codes will clear automatically once the pipe refills with liquid. It is not recommended to mount the transducers in an area where the pipe may become partially filled. Partially filled pipes will cause erroneous and unpredictable operation of the meter.

A piping system that contains lengths of straight pipe such as those described in Table 2.1. The optimum straight pipe diameter recommendations apply to pipes in both horizontal and vertical orientation. The straight runs in Table 2.1 apply to liquid velocities that are nominally 7 FPS [2.2 MPS]. As liquid velocity increases above this nominal rate, the requirement for straight pipe increases proportionally.

Mount the transducers in an area where they will not be inadvertently bumped or disturbed during normal operation.

Avoid installations on downward flowing pipes unless adequate downstream head pressure is present to overcome cavitations in the pipe.

Piping configuration And transducer position	Upstream Dimension	Downstream Dimension
	Pipe Diameters(*)	Pipe Diameters (**)
	10	5
	14	5
	24	5
	30	5
	10	5
	24	10

Table 2.1 Straight Pipe Requirement

2.3 TRANSDUCER SPACING

CLAMP-ON 1100 transducers are clamped on the outside of a closed pipe **at a specific distance from each other**. The transducers can be mounted in V-mode where the sound transverses the pipe two times, W-mode where the sound transverses the pipe four times, or in Z-mode where the transducers are mounted on opposite sides of the pipe and the sound crosses the pipe once. For further details, reference pictures located under **Table 2.2**. The appropriate mounting configuration is based on pipe and liquid characteristics. Selection of the proper transducer mounting method is not entirely predictable and many times is an iterative process. **Table 2.2** contains recommended mounting configurations for common applications. These recommended configurations may need to be modified for specific applications if such things as aeration, suspended solids or poor piping conditions are present. W-mode provides the longest sound path length between the transducers - but the weakest signal strength. Z-mode provides the strongest signal strength - but has the shortest sound path length. On pipes smaller than 75 mm, it is desirable to have a longer sound

path length, so that the differential time can be measured more accurately.

**Table 2.2
Transducer Mounting Modes**

Transducer Mount Mode	Pipe Material	Pipe Size	Liquid Composition
W-Mode	Plastic (all types)	1-6 in. (25-150 mm)	Low TSS; non-aerated
	Carbon Steel	1-4 in. (25-100 mm)	Low TSS; non-aerated
	Stainless Steel	1-6 in. (25-150 mm)	Low TSS; non-aerated
	Copper	1-6 in. (25-150 mm)	Low TSS; non-aerated
	Ductile Iron	Not recommended	
	Cast Iron	Not recommended	
V-Mode	Plastic (all types)	6-30 in. (150-750 mm)	Low TSS; non-aerated
	Carbon Steel	4-24 in. (100-600 mm)	Low TSS; non-aerated
	Stainless Steel	6-30 in. (150-750 mm)	Low TSS; non-aerated
	Copper	6-30 in. (150-750 mm)	Low TSS; non-aerated
	Ductile Iron	3-12 in. (75-300 mm)	Low TSS; non-aerated
	Cast Iron	3-12 in. (75-300 mm)	Low TSS; non-aerated
Z-Mode	Plastic (all types)	> 30 in. (> 750 mm)	Low TSS; non-aerated
	Carbon Steel	> 24 in. (> 600 mm)	Low TSS; non-aerated
	Stainless Steel	> 30 in. (> 750 mm)	Low TSS; non-aerated
	Copper	> 30 in. (> 750 mm)	Low TSS; non-aerated
	Ductile Iron	> 12 in. (> 300 mm)	Low TSS; non-aerated
	Cast Iron	> 12 in. (> 300 mm)	Low TSS; non-aerated

TSS = Total Suspended Solids

Transducer Mounting Modes

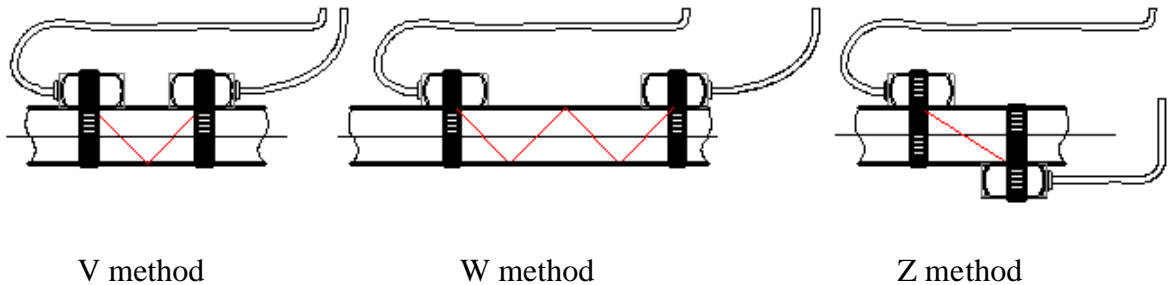

The CLAMP-ON 1100 system calculates proper transducer spacing by utilizing piping and liquid information entered by the user.

The following information is required before programming the instrument. Note that much of the data relating to material sound speed, viscosity and specific gravity are preprogrammed into the CLAMP-ON 1100 flow meter. This data only needs to be modified if it is known that a particular liquid data varies from the reference value. Refer to Part 3 of this manual for instructions on entering configuration data into the CLAMP-ON 1100 flow meter via the meter keypad. Transducer mounting configuration. See Table 2.2 on Page 7

1. Pipe Outer Diameter)
2. Pipe wall thickness
3. Pipe material

4. Pipe sound speed
5. Pipe relative roughness
6. Pipe line thickness
7. Pipe line material
8. Pipe line sound speed
9. Fluid type
10. Fluid sound speed

Nominal values for these parameters are included within the CLAMP-ON 1100 operating system. The nominal values may be used as they appear or may be modified if exact system values are known.

After entering the data listed above, the CLAMP-ON 1100 will calculate proper transducer spacing for the particular data set. This distance will be in inches if the CLAMP-ON 1100 is configured in English units, or millimeters if configured in metric units.

2.4 TRANSDUCER MOUNTING

After selecting an optimum mounting location and successfully determining the proper transducer spacing, the transducers may now be mounted onto the pipe.

The transducers must be properly oriented on the pipe to provide optimum reliability and performance. On horizontal pipes, the transducers should be mounted 180 radial degrees from one another and at least 45 degrees from the top-dead-center and bottom-dead-center of the pipe. See Figure 2.1. Figure 2.1 does not apply to vertically oriented pipes.

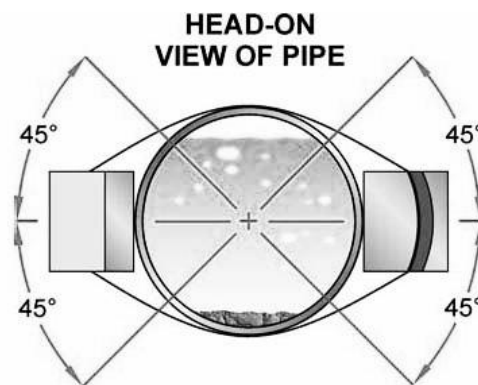

Figure 2.1
Transducer Orientation—Horizontal Pipes

On vertical pipes the orientation does not apply.

Pipe Preparation

Before the transducers are mounted onto the pipe surface, two areas slightly larger than the flat surface of the transducer heads must be cleaned of all rust, scale and moisture. For pipes with rough surfaces, such as ductile iron pipe, it is recommended that the pipe surface be ground flat. Paint and other coatings, if not flaked or bubbled, need not be removed.

Plastic pipes typically do not require surface preparation other than soap and water cleaning.

Observe Signal Strength while placing the transducers into position. Signal Strength can be displayed on Menu 90.

V-Mode and W-Mode Installation

1. For CLAMP-ON 1100 transducers, place a single bead of couplant, approximately 1.2 mm thick, on the flat face of the transducer. Generally, silicone-based grease is used as an acoustic couplant, but any grease-like substance that is rated not to “flow” at the temperature that the pipe may operate will be acceptable.

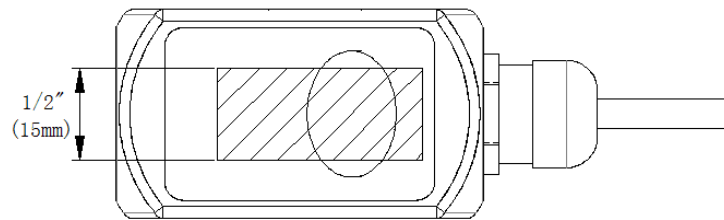

Figure 2.2

2. Place the upstream transducer in position and secure with a mounting strap. Straps should be placed in the arched groove on the end of the transducer. A screw is provided to help hold the transducer onto the strap. Verify that the transducer is stick to the pipe - adjust as necessary. Tighten the transducer strap securely.
3. Place the downstream transducer on the pipe at the calculated transducer spacing. See **Figure 2.3**. Using firm hand pressure, slowly move the transducer both towards and away from the upstream transducer while observing Signal Strength. Clamp the transducer at the position where the highest Signal Strength is observed. A Signal Strength (Menu 90) between 60 and 95 is acceptable.
4. If after adjustment of the transducers the Signal Strength (Menu 90) does not rise to above 60, then an alternate transducer mounting method should be selected. If the mounting method was W-mode, then reconfigure the CLAMP-ON 1100 for V-mode, reset the CLAMP-ON 1100, move the downstream transducer to the new location and repeat step 3.

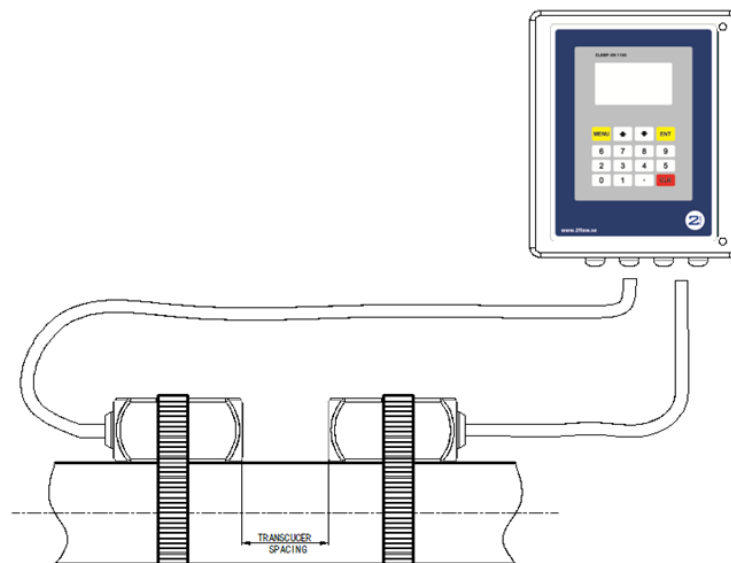

Figure 2.3 Transducer position

V-Mount is the STD installation method, it is convenient and accurate, Reflective type (transducers mouthed on one side of the pipe) of installation used primarily on pipe size in the (50mm~400mm) internal diameter range attention transducer designed parallel on the centre line of installing the pipeline.

The spacing value shown on menu window M25 refers to the distance of inner spacing between the two transducers. The actual transducers spacing should be as close as possible to the spacing value. The transducer spacing is from the end of one transducer to another sensor.

The transducer mounting spacing is very important for Transit-time meters, and users need mount transducers exactly according to the spacing distance value M25 displays after users input proper parameter settings. M91 is only for reference, and just keep it within 97--103% value range.

As the above figure shows, the normal transducer spacing refers to the distance between the ends of the two transducers (as the two red lines indicate). And this spacing should be exactly according to the value M25 tells you. Note that this method suits for normal Small, Std. M and Large transducer.

Mounting Transducers in Z-Mount Configuration

Installation on larger pipes requires careful measurements to the linear and radial placement of the L1 transducers. Failure to properly orient and place the transducers on the pipe may lead to weak signal strength and/or inaccurate readings. The section below details a method for properly locating the transducers on larger pipes. This method requires a roll of paper such as freezer paper or wrapping paper, masking tape and a marking device.

1. Wrap the paper around the pipe in the manner shown in **Figure 2.4**. Align the paper ends to within 6 mm.
2. Mark the intersection of the two ends of the paper to indicate the circumference.

Remove the template and spread it out on a flat surface. Fold the template in half, bisecting the circumference. See **Figure 2.5**.

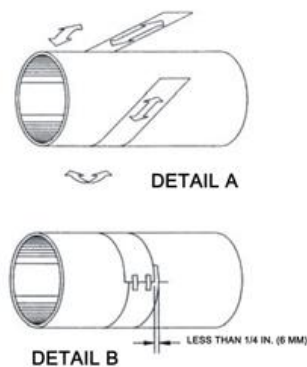

Figure 2.4
Paper Template Alignment

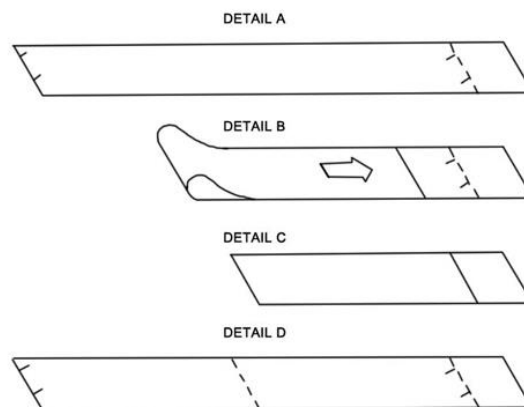

Figure 2.5
Bisecting the pipe circumference

3. Crease the paper at the fold line. Mark the crease. Place a mark on the pipe where one of the transducers will be located. See **Figure 2.1** for acceptable radial orientations. Wrap the template back around the pipe, placing the beginning of the paper and one corner in the location of the mark. Move to the other side of the pipe and mark the pipe at the ends of the crease. Measure from the end of the crease directly across the pipe from the first transducer location) the dimension derived in Step 2, Transducer Spacing. Mark this location on the pipe.

4. The two marks on the pipe are now properly aligned and measured.

If access to the bottom of the pipe prohibits the wrapping of the paper around the circumference, cut a piece of paper to these dimensions and lay it over the top of the pipe.

Length = Pipe O.D. x 1.57; width = Spacing determined on page 2.6

Mark opposite corners of the paper on the pipe. Apply transducers to these two marks.

5. Place a single bead of couplant, approximately 1.2 mm thick, on the flat face of the transducer. See **Figure 2.2**. Generally, a silicone-based grease is used as an acoustic couplant, but any grease-like substance that is rated to not “flow” at the temperature that the pipe may operate at, will be acceptable.

a) Place the upstream transducer in position and secure with a stainless steel strap or other. Straps should be placed in the arched groove on the end of the transducer. A screw is provided is provided

b) Try to help hold the transducer onto the strap. Verify that the transducer is true to the pipe - adjust as necessary. Tighten transducer strap securely. Larger pipes may require more than one strap to reach the circumference of the pipe.

6. Place the downstream transducer on the pipe at the calculated transducer spacing. See **Figure 2.6**. Using firm hand pressure, slowly move the transducer both towards and away from the upstream transducer while observing Signal Strength. Clamp the transducer at the position where the highest Signal Strength is observed. Signal Strength of between 60 and 95 percent is acceptable. On certain pipes, a slight twist to the transducer may cause signal strength to rise to acceptable levels.

7. Secure the transducer with a stainless steel strap or other.

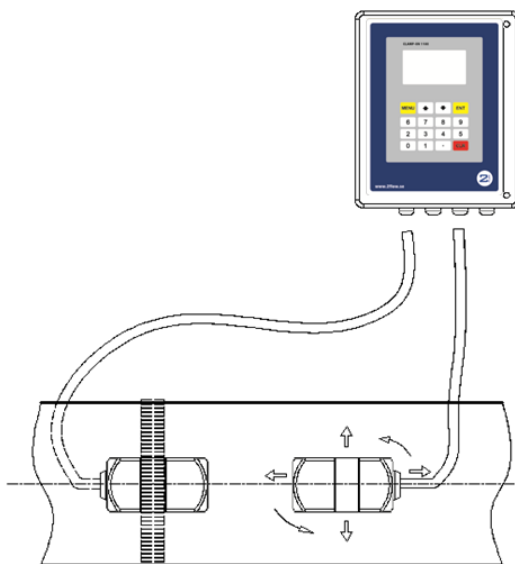

Figure 2.6
Z-Mode transducer placements

2.5 TRANSDUCER MOUNTING INSPECTION AND COUPLANT APPLICATION

2.5.1 Transducer Mounting Inspection

It is very important to use menu operations for TRANSDUCER MOUNTING INSPECTION and Estimation, Refer to 5.16, Use menu windows for Transducer Mounting Inspection.

2.5.2 Couplant Application

A, It is also very important for couplant application.

When mounting the transducers, apply just enough pressure so that the couplant fills the gap between the pipe and transducer. Commonly, the Dow 732 for permanent and Dow 111 for temporary installations, but Dow 111 has a better coupling effect. If Dow 732 was used, ensure that no relative movement between the transducer and the pipe takes place during the setting time and do not apply instrument power for at least 24 hours, Dow 111 also be used for permanent installations(avoid rain or water etc.), setting time is not necessary. We recommend using Dow 111 for permanent installing, and then use Dow732 around the transducer in order to fix the transducer, waterproof cloth is recommended if the Transducers are installed outdoor. Dow 112 for high temperature application.

B, Transducers for High Temperature

Mounting of high temperature transducers is similar to CLAMP-ON 1100 standard transducers; High temperature installations require acoustic couplant Dow Corning 112 that is rated not to flow at the temperature that will be present on the pipe surface.

PART-3 TRANSMITTER INSTALLATION CONNECTION AND OPERATION INSTRUCTIONS

3.1 TRANSMITTER INSTALLATION

After unpacking, it is recommended to save the shipping carton and packing materials in case the instrument is stored or re-shipped. Inspect the equipment and carton for damage. If there is evidence of shipping damage, notify the carrier immediately.

The enclosure should be mounted in an area that is convenient for servicing, calibration or for observation of the LCD readout (if so equipped).

1 Locate the transmitter within the length of transducer cable that was supplied with the CLAMP-ON 1100 system. If this is not possible, it is recommended that the cable be exchanged for one that is of proper length. Transducer cables that are up to 300 meters may be accommodated.

2. Mount the CLAMP-ON 1100 transmitter in a location that is:

- ◆ Where little vibration exists.
- ◆ Protected from falling corrosive fluids.
- ◆ Within ambient temperature limits -20 to 60°C
- ◆ Out of direct sunlight. Direct sunlight may increase transmitter temperature to above the maximum limit.

3. Mounting: Refer to **Figure 3.1** for enclosure and mounting dimension details. Ensure that enough room is available to allow for door swing, maintenance and conduit entrances. Secure the enclosure to a flat surface with four appropriate fasteners.

4. Conduit holes. Conduit hubs should be used where cables enter the enclosure. Holes not used for cable entry should be sealed with plugs.

NOTE: Use NEMA 4 [IP65] rated fittings/plugs to maintain the water tight integrity of the enclosure. Generally, the left conduit hole (viewed from front) is used for line power; the center conduit hole for transducer connections and the right hole are utilized for OUTPUT wiring.

5 If additional holes are required, drill the appropriate size hole in the enclosure's bottom. Use extreme care not to run the drill bit into the wiring or circuit cards.

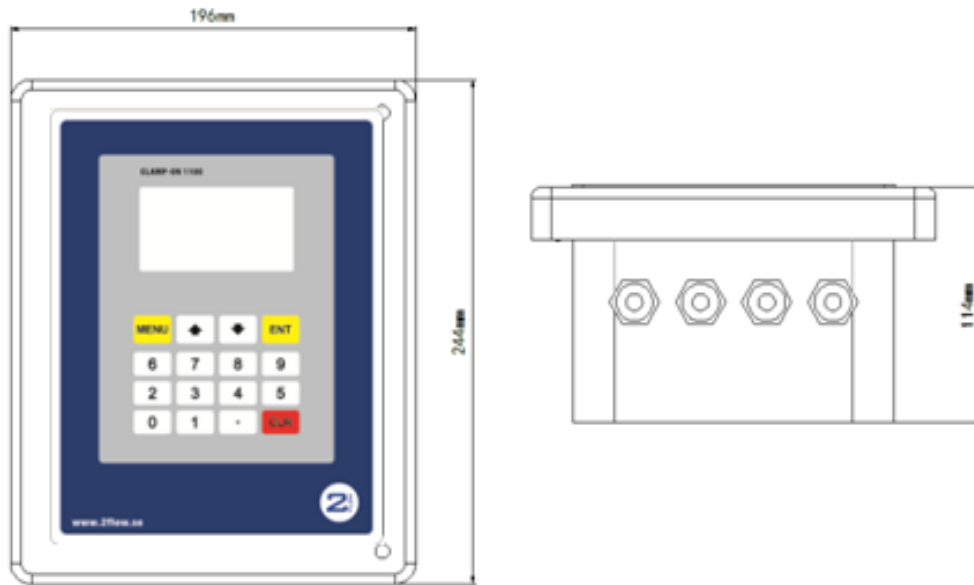

Figure 3.1 Mechanical Dimensions

3.2 TRANSDUCER CONNECTIONS

To access terminal strips for electronic connectors, loosen the two screws in the enclosure door and open the door.

Guide the transducer terminations through the transmitter conduit hole located in the bottom-center of the enclosure.

The terminals within CLAMP-ON 1100 are a pluggable type - they can be removed wired and then plugged back in. Connect the appropriate wires to the corresponding screw terminals in the transmitter. Observe UP/DN transducers orientation (if flow rate display negative, exchange the UP/ DOWN wiring).



Red Silver Black

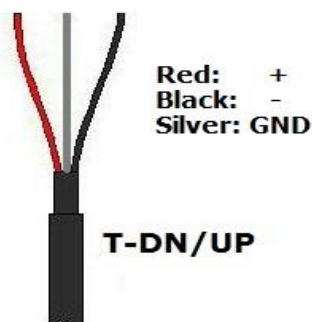

Figure 3.2

NOTE: The transducer cable carries low level high frequency signals. In general, it is not

recommended to add additional cable to the cable supplied with the transducers. If additional cable is required, contact the factory to arrange an exchange for a transducer with the appropriate length of cable.

Cables to 300 meters are available.

3.3 TRANSMITTER POWER AND OUTPUT CONNECTIONS

1, Connect line power to the screw terminals AC, GND or DC in the transmitter. See the Figure 3.2, the ground terminal grounds the instrument, which is mandatory for safe operation.

DC Power connection: The CLAMP-ON 1100 can be operated from a 9-28 VDC source, as long as the source is capable of supplying a minimum of 3 Watts.

NOTE: This instrument requires clean electrical line power. Do not operate this unit on circuits with noisy components (i.e., fluorescent lights, relays, compressors, or variable frequency drives). It is recommended not to run line power with other signal wires within the same wiring tray or conduit.

2, Connect the 4~20mA wires to the appropriate (4~20mA + -) (The 4-20 mA output do not requires power from an external DC power supply)

3, OCT1 can be setting as Pluse and Frequency in menu78. OCT2 can be setting as Relay in menu79. And the OCT1 and OCT are interchangeable.

Pulse output is **Only For Flow Rate Output.**

The pulse output is utilized to transmit information to external counters and PID systems via a frequency output that is proportional to system flow rate. The frequency output range of the Pulse is 0–9,999 Hz.

The type of pulse output is an open-collector transistor (OCT) type that requires an external power source and pull-up resistor. External DC power Supply is depending on Pulse Output receiver, 5-24V is allowable.

4, OCT2 for Relay “+, -”, **only For Totalizer Output or Relay Alarm Output.**

Once the transmitter is powered on, the “RELAY +, -” output is normally Open state.

When the relay is used for totalizer output, connect terminal “OCT2 + -“, select the corresponding totalizer in Menu 79, and setup the minimum display totalizer increments in Menu 33. Every time the totalizer increases a value set in M33, the relay closed one time.

When the relay is used for alarm output, connect terminal “OCT2 + -“, select the corresponding item in Menu 79, it can be used for several alarm condition. For example, select “Alarm #1”, set “Alarm #1 Low Value” in Menu 73, and set “Alarm #1 High Value” in Menu 74. When the flow is between the low value and high value, the relay is open state, and when the flow is lower than “Low Value”, or higher than “High Value”, the relay is closed state.

5, RS232C or RS485 wiring:

CLAMP-ON 1100 Series provide RS232C or RS485 communication output based on user’s option. RS485 output wiring terminals is A and B see the Fig. 3.2.

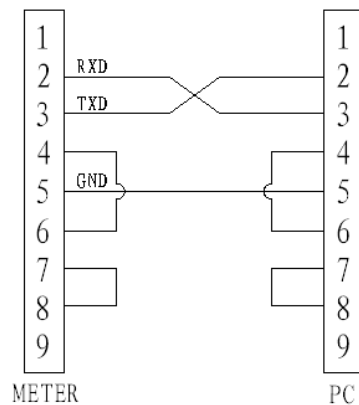

6, RS485 (Modbus-RTU) wiring:

CLAMP-ON 1100 series default Modbus output is Modbus-RTU protocol, Modbus-ASCII protocol can be optional when you place order.

When connect wirings, the “D+” terminal is connected to modbus “A”, and the “D-” terminal is connected to modbus “B”. (More details in APPENDIX 4 MODBUS-RTU COMMUNICATIONS PROTOCOL)

3.4 KEYPAD CONFIGURATION

3.4.1, Keypad functions

After transducer and connection of appropriate power supply to CLAMP-ON 1100, keypad configuration of the instrument can be undertaken. Generally, there should be no display of error messages, and the flow meter will go to the most commonly used Menu Window Number 01 (short for M01) to display the Velocity, Flow Rate, Positive Totalizer, Signal Strength and Signal Quality, based on the pipe parameters entering by the user or by the initial program.

The CLAMP-ON 1100 contains a 16-key tactile keypad, allows the user to view and change configuration parameters as shown below.



Follow these guidelines when using CLAMP-ON 1100 keypad:

~ and to input numbers and decimal.

◀ to backspace or delete characters to the left.

The ARROW keys and To return to the last menu or to open the next menu, are used to scroll through menu configuration parameters; also acts as “+” and “-” functions when entering numbers.

To select a menu. Press this key first, input two menu numbers and then enter the selected menu. For instance, to input a pipe Outside diameter, press keys, where “12” is the window Address to display the parameter pipe wall thickness.

3.4.2 KEYPAD OPERATION

With all of the parameters entered, the instrument setup and measurement displays are subdivided or consolidated into more than 100 independent windows. The user can view the window menu, input parameters, modify settings or display measurement results. These windows are arranged by 2-digit serial numbers (including sign) from 00~99, then to , , etc.. Every window serial number, or so-called window Address code, has a defined meaning. For instance, Window No.11 indicates the parameter input for pipe outside diameter, while Window No.25 indicates the mounting distance between the transducers, etc. (Refer to Part 4 – Windows Display Explanations).

The keypad shortcut to visit a specific window is to press the key at any time, then input the 2-digit window Address code. For instance, to input or check the pipe outside diameter, just press the , , keys for window Address code 11.

Another method to visit a particular window is to press , and keys to scroll the menu. For instance, if the current window Address code is 66, press key to enter Window No.65, press the again to enter Window No.64; then, press the key to back Window No.65, and press the key again to enter Window No.66.

Example 1. To enter a pipe outside diameter of 218.6, the procedure is as follows:

Press **MENU** **1** **1** keys to enter Window No.11 (the numerical value displayed currently is a previous value). Now press **ENTER** key. The symbol **>** and the flashing cursor are displayed at the left end of the second line on the Screen. The new value can be entered by press **2** **1** **8** **.** **6** **ENTER**.

M11
Outer Diameter
108 mm

M11
Outer Diameter
108 mm
> 218.6

Example 2. If the pipe material is “Stainless Steel”, press keys **MENU** **1** **4** to enter Window No.14 first. Then press **ENTER** key to modify the options. Now, select the “1. Stainless Steel” option by pressing **^** and **v** keys, and then press **ENTER** key to confirm the selection. It is possible to press the key **1** to change the selection and wait until “1. Stainless Steel” is displayed on the second line of the screen. Then press the **ENTER** key to confirm.

Generally, press **ENTER** key first if operator wants to enter “modify” condition. If the “modify” is still not possible even after pressing the **ENTER** key, it means that system is locked by a password. To “Unlock” it, Select “Unlock” in Window No. 47 and enter the original password. The keypad will not respond if the keypad is locked. It only can be unlocked by the entering original password. Select keypad lock functions in Window No. 48. Please consult factory for password if necessary.

3.4.3 CLAMP-ON 1100 Window Descriptions

The CLAMP-ON 1100 has a unique feature of windows processing for all operations.

These windows are assigned as follows:

00~08 windows for the display of flow rate, velocity, positive total, negative total, net total, heat flow, date & time, meter run status etc.

11~29 windows for initial Parameter Setup: To enter pipe outside diameter, pipe wall thickness, pipe material type, fluid type, transducer type, etc. For CLAMP-ON 1100C, pipe material type selection is not necessary.

30~38 windows for flow Units Options: to select the flow unit, totalizer unit, measurement unit, turn totalizers on/off and reset totalizes, etc.

40~49 windows for Setup options: Scale factor, network IDN (Window No.46), system lock (Window No.47) and keypad lock code (Window No.48), etc.

50~89 windows for Input and output setup: relay output setup, 4-20mA outputs, flow batch controller, LCD backlit option, date and time, low/high output frequency, alarm output, date totalizer, etc.

90~94 windows for Diagnoses: Signal strength and signal quality (Window No.90), **TOM/TOS*100 (Window No.91)**, flow sound velocity (Window No.92), total time and delta time (Window No.93), Reynolds number and factor (Window No.94), etc.

^0~^8 APPENDIX: Power on/off time, total working hours, on/off times and hardware adjustment, used by the manufacturer only. For further information, please refer to **Part 4 – Windows Display Explanations**. If you have any questions, refer to the step-by-step instructions found in the following section (**3.4.4 Pipe Parameter Entry Shortcuts**).

In fact, users don't need to set up so many steps, just select necessary parameters to set up in the menu.

3.4.4 Pipe Parameter Entry Shortcuts

The following parameters should be entered for normal measurement:

1. Pipe outer diameter
2. Pipe wall thickness
3. Pipe material
4. Liner material parameters (including thickness and sound velocity, if needed)
5. Fluid type
6. Transducer type (The transmitter is available for various transducer types, for CLAMP-ON 1100, opt. S, M, L, Plug-in type B45 is for insertion transducer)
7. Transducer mounting methods (refer to **Part 2, W, V, Z**)
- 8. For the CLAMP-ON 1100V, Clamp-on transducers, the M25 displayed the transducers spacing (two transducers installing distance) should be strictly abode. Also user shall refer to M91 and keep the value of M91 to 97%-103. %.**

In the order stated above, enter the above-mentioned parameters by the following keypad shortcuts:

1. Press **MENU** **1** **1** keys to enter Windows No.11, and enter the pipe outside diameter, and then press the ENTER key.
2. Press the **▽** key to enter Window No.12, pipe wall thickness, and press **ENTER** key.
3. Press the **▽** key to enter Window No.14, press the **ENTER** key, move the **△** or **▽** key to select pipe material, and press the ENTER key.
4. Press the **▽** key to enter Window No.16, press the **ENTER** key, move the **△** or **▽** key

to select liner material, and press the ENTER key.

5. Press the ∇ key to enter Window No.20, press the ENTER key, move the \wedge or ∇ key to select fluid type, press the ENTER key.

6. Press the ∇ key to enter Window No. 23, press the ENTER key, move the \wedge or ∇ key to select transducer type, and press the ENTER key.

7. Press the ∇ key to enter Window No.24, press the ENTER key, move the \wedge or ∇ key to select transducer-mounting method, and press the ENTER key.

8. Press the ∇ key to enter Window No.25, accurately install the transducer according to the displayed transducer mounting spacing and the selected mounting method (Refer to Installing the Transducers in Part 2).

9. Press the MENU 0 1 keys to enter Window No.01 to display measurement result.

10. Press the MENU X X keys to directly enter Window No.XX to display Mxx contents, where X is digital number on keypad.

PART-4 WINDOWS DISPLAY EXPLANATIONS

Windows Display Explanations

Menu Window Numbers	Functions/Display								
M00	Positive, negative, net total flow and run status								
M01	Positive total flow, flow rate , fluid velocity and run status								
M02	Negative total flow, flow rate , fluid velocity and run status								
M03	Net total flow, flow rate , fluid velocity and run status								
M04	Date, time, flow rate, run status								
M05	<p>Total heat flow , heat flow rate, fluid velocity and run status</p> <table border="1" style="margin-left: auto; margin-right: auto;"> <tr> <td>EFR</td> <td>0.0000kW</td> </tr> <tr> <td>E.T</td> <td>0E0kWh</td> </tr> <tr> <td>Vel</td> <td>0.0000 m/s</td> </tr> <tr> <td>S=00.0, 00.0</td> <td>Q=00</td> </tr> </table>	EFR	0.0000kW	E.T	0E0kWh	Vel	0.0000 m/s	S=00.0, 00.0	Q=00
EFR	0.0000kW								
E.T	0E0kWh								
Vel	0.0000 m/s								
S=00.0, 00.0	Q=00								
M06	Tin/Tout temperature value (4-20mA temperature sensor input for Heat flow measurement)								
M07	Meter run Error Code and run status								
M08	Net total flow today								
Above is display menu(M00-M08)									
M11	Window for entering/changing the outside (outer) diameter of the pipe line. 0 to 4500 mm is the allowed range of the value.								
M12	Window for entering pipe wall thickness								
M13	Window for entering the inside(inner) diameter of the pipe(If user had entered the parameters of M11 and M12, M13 is not necessary to enter, automatically display and can't change)								
M14	<p>Window for selecting pipe material, familiar pipe materials include: (The materials must be equable, compact and can transmit ultrasound)</p> <p>0. Carbon steel 1. Stainless steel 2. Cast iron 3. Ductile iron 4. Copper 5. PVC 6. Aluminum 7. Asbestos 8. Fiberglass 9. Others</p>								
M16	Window for selecting the liner material, select none for pipes								

	without any liner. familiar liner materials include: 0. No liner 1. Tar Epoxy 2. Rubber 3. Mortar 4. Polypropylene 5. Polystryol 6. Polystyrene 7. Polyester. 8. Polyethylene 9. Ebonite 10. Teflon 11. Others
M18	Window for entering the liner thickness, if there is liner
M20	Window for selecting fluid type familiar liquids types include: 0. Water 1. Sea Water 2. Kerosene 3. Gasoline 4. Fuel oil 5. Crude Oil 6. Propane at -45°C 7. Butane at 0°C 8. Other * 9. Diesel Oil 10. Castor Oil 11. Peanut Oil 12. #90 Gasoline 13. #93 Gasoline 14. Alcohol 15. Hot water at 125 °C
M21	Window for entering the Fluid Sound Speed, only for “other” liquids. If M20 select “other”, user must enter the fluid sound velocity (inquiry or estimate a suitable value); if you do not select “other” in Menu 20, M21 won’t appear.
M22	Window for entering the viscosity of the “other” liquids, unit of viscosity is cst. If you do not select “other” in Menu 20, M21 won’t appear.
M23	Window for selecting the proper transducer type (XDCR Type), There are different types of transducers for. For CLAMP-ON 1100V, opt. Standard-S, Standard-M, standard-L, Plug-in type B45 is for insertion transducer. <div style="border: 1px solid black; padding: 5px; margin: 10px auto; width: fit-content;"> M23 XDCR Type 0. Standard-M </div> Standard-S: Clamp-on small pipe, 20-40mm Standard-M: Clamp-on standard pipe, 40-1000mm Standard-L: Clamp-on large pipe, 1000mm-4500mm Plug-in B45: Insertion, hot-tapped transducer, 65-4500mm
M24	Window for selecting the transducer mounting method (XDCR Mounting). Four methods can be selected: 0. V-method 1. Z-method 2. N-method 3. W-method

<p style="text-align: center;">M25</p> <p>*Important</p>	<p>Display the transducer mounting spacing.</p> <p>Users need mount transducers exactly according to the spacing distance value M25 displays after users input correct parameter setting.</p>
<p style="text-align: center;">M26</p>	<p>Entry to store the parameter configurations into the internal memory. This is very important step, otherwise, if power off and power on again, the meter may can't memory the parameter configurations.</p>
<p style="text-align: center;">M27</p>	<p>Display liquid cross section area, provide user to validate flow rate or total flow display, commonly it's no matter with user.</p>
<p style="text-align: center;">M28</p>	<p>Hold poor signal, YES is the default setup. If poor signal appears, meter still have a previous read. Commonly, don't change the default setup.</p>
<p style="text-align: center;">M29</p>	<p>Empty Pipe Setup, this is very useful for user, Empty pipe line or pipe shaking etc., meter may display error or undesired read, user can setup a Q value less than normal Q value, for example, normal Q value is 60-70, user can enter Empty Pipe Setup value 50, such, meter will display 0 flow rate when Q value is less than 50. In good pipe status, please do not setup this value too small.</p>
<p>Above is initial parameter setup (M11-M29)</p>	
<p style="text-align: center;">M30</p>	<p>Window for selecting Measurement Unit system. Default value is 'Metric'. The change from English to Metric or vice versa will not affect the unit for totalizers.</p>
<p style="text-align: center;">M31</p>	<p>Window for selecting Flow Rate Unit,</p> <div style="border: 1px solid black; padding: 5px; width: fit-content; margin: 10px auto;"> <p style="text-align: center;">M31 Flow Rate Unit M3/h</p> </div> <p>To change it, press key "ENTER", will display:</p> <div style="border: 1px solid black; padding: 5px; width: fit-content; margin: 10px auto;"> <p style="text-align: center;">M31 Flow: Units/T > Cubic Meters</p> </div> <p style="text-align: right;">The > is flashing, press scroll key ^ or v to select desired unit, then press "ENTER", to select time unit will display:</p>

	<div style="border: 1px solid black; padding: 5px; width: fit-content;"> M31 Cubic Meters > /T </div> <p>Flow rate unit can be in</p> <table border="0"> <tr> <td>0. Cubic Meters</td> <td>short for</td> <td>(m3)</td> </tr> <tr> <td>1. Liter</td> <td></td> <td>(l)</td> </tr> <tr> <td>2. American Gallon</td> <td></td> <td>(gal)</td> </tr> <tr> <td>3. Imperial Gallon</td> <td></td> <td>(igl)</td> </tr> <tr> <td>4. Million Gallon (American)</td> <td></td> <td>(mgl)</td> </tr> <tr> <td>5. Cubic Feet</td> <td></td> <td>(cf)</td> </tr> <tr> <td>6. American Liquid Barrel</td> <td></td> <td>(bal)</td> </tr> <tr> <td>7. Imperial Liquid Barrel</td> <td></td> <td>(ib)</td> </tr> <tr> <td>8. Oil Barrel</td> <td></td> <td>(ob)</td> </tr> </table> <p>The flow unit in terms of time can be per day, per hour, per minute or per second. So there are 36 different flow rate units in total for selection.</p>	0. Cubic Meters	short for	(m3)	1. Liter		(l)	2. American Gallon		(gal)	3. Imperial Gallon		(igl)	4. Million Gallon (American)		(mgl)	5. Cubic Feet		(cf)	6. American Liquid Barrel		(bal)	7. Imperial Liquid Barrel		(ib)	8. Oil Barrel		(ob)	<p>The > is flashing, press scroll key \wedge or \vee to select desired time unit, then press “ENTER”, then. Will display desired flow rate unit.</p>
0. Cubic Meters	short for	(m3)																											
1. Liter		(l)																											
2. American Gallon		(gal)																											
3. Imperial Gallon		(igl)																											
4. Million Gallon (American)		(mgl)																											
5. Cubic Feet		(cf)																											
6. American Liquid Barrel		(bal)																											
7. Imperial Liquid Barrel		(ib)																											
8. Oil Barrel		(ob)																											
M32	Window for selecting Totalizers Unit, working unit default is cubic meters, if change it, press ENTER, then press scroll key \wedge or \vee , to select desired unit.																												
M33	Select Totalizer Multiplier The multiplier ranges from 0.001 to 10000, default value is $\times 1$, addition, if select total flow pulse output, this value represent one pulse corresponding value.																												
M34	Turn on or turn off the NET Totalizer																												
M35	Turn on or turn off the Positive Totalizer																												
M36	Turn on or turn off the Negative Totalizer																												
M37	Totalizer Reset, the following options are available: No YES Restore the instrument to the default parameters as the manufacturer did (Reset system) by pressing the dot key \square followed by the \blacktriangleleft key. Take care or make note on the																												

	parameters before doing restoration
M38	<p>The Manual Totalizer is a separate totalizer, press “ENTER” to start, and press “ENTER” to stop it. It is used for flow measurement, calculation and manual calibration.</p> <p>Press ENTER When Ready.</p>
Above is flow units options(M30-M38)	
M40	<p>Flow rate Damping for displaying a stable read. The input range is 0 to 999 seconds.</p> <p>0 means there is no damping. Default value is 10 seconds; common setup value is 1-10 seconds.</p>
M41	<p>Low Flow Cutoff, may be used in order to force a zero display at lower flows and avoid incorrect totalizer.</p> <p>For instance, this value is 0.02m/s, the meter will display zero when flow rate is less than $\pm 0.02\text{m/s}$.</p> <div style="border: 1px solid black; padding: 5px; width: fit-content; margin-left: auto; margin-right: auto;"> <p>M41 Low Flow Cutoff 0.02m/s</p> </div>
M42	<p>Set Zero, when the fluid is in the static state, the displayed value is called “zero point”. When the “Zero Point” is not really at zero, the incorrect read value is going to be added into the actual flow values.</p> <p>Set Zero must be carried out after the transducers are right installed and the flow inside is in the absolute static state (no liquid moved in the pipe line). Set Zero also is very important step when recalibrating the meter in lab. Doing this step enhances the measuring accuracy and flow offset can be eliminated.</p>
M43	<p>Reset Zero, clear the zero point set by the user, and restore the zero point set by the manufacturer.</p>
M44	<p>Manual Zero Point. Set up a manual flow offset. Generally this value should be 0.</p>
M45	<p>The Scale Factor is used to modify the measurement results, factory default is 1.0 or other value depend on calibration, please see the calibration data sheet and save this sheet. If really necessary, the user can enter a numerical value other than factory default value according to re-calibration results.</p>

M46	Network environment Identification Number for PC communication system.
M47	System Lock, to avoid modification of the parameters, contact factory for the password.
M48	Keypad Lock Code, enter a password in order to prevent unauthorized keypad operating. Unlock it only using the correct password. If forgot, contact factory for the password to unlock it.
M49	Comm. Test, for communication test.
M50	<p>Data Logger Option,</p> <div style="border: 1px solid black; padding: 5px; width: fit-content; margin-left: auto; margin-right: auto;"> M50 Logger Option ON </div> <p>If select data logger output, please select “ON”, then, press “ENTER”.</p>
M51	<p>Time setup for the data logger Set up Start time and Interval,</p> <div style="border: 1px solid black; padding: 5px; width: fit-content; margin-left: auto; margin-right: auto;"> M51 Logger Time Start 00:00:00 Interval 00:00:00 Go On 00:00:00 </div> <p>if “Go On” time is longer than 24 hours, please use dot key <input type="text" value="."/> on Keypad, as below: **:**:** Means it is no time limit.</p> <div style="border: 1px solid black; padding: 5px; width: fit-content; margin-left: auto; margin-right: auto;"> M51 Logger Time Start 12:30:00 Interval 00:05:00 Go On **:**:** </div>
M52	Data logging direction control: Only Select ‘To RS-232’ is selected, all the data produced by the data logger will be transmitted out through the RS-232 interface.
M53	<p>CL Calibration 4-20mA output calibration, Press ENTER when ready Meter window will display: Use a Ammeter to verify</p> <div style="border: 1px solid black; padding: 5px; width: fit-content; margin-left: auto; margin-right: auto;"> M53 CL Calibration Pre ENT When Ready </div>

	<p>4mA output, if not, use key \wedge or \vee, let the output is 4.0mA</p> <p>Use the same way, let the Output is 20.0mA</p> <p>This function mainly used by CLAMP-ON 1100manufacturer.</p>	<div style="border: 1px solid black; padding: 5px; margin-bottom: 10px;"> M53 CL Calibration 4mA==>-035_ </div> <div style="border: 1px solid black; padding: 5px;"> M53 CL Calibration 20mA==>-100_ </div>
M54	<p>CL Mode Select</p> <p>Select Current Loop output mode</p> <p>Use key \wedge or \vee, can select different mode:</p> <p>4-20MA, 0-4-20MA, 0-20MA, 20-4-20MA etc.</p> <p>It is useful if negative flow occurs.</p> <p>For instance, select 0-4-20MA output; user can define 0-4MA as negative flow, 4-20MA as positive flow.</p>	<div style="border: 1px solid black; padding: 5px;"> M54 CL Mode Select 0. 4-20mA </div>
M55	<p>CL(Current Loop) 4 MA output Value</p> <p>The flow unit's options are the same as those in Menu 31.</p>	<div style="border: 1px solid black; padding: 5px;"> M55 CL 4mA OutputVal 0 m3/h </div>
M56	<p>CL(Current Loop) 20MA output Value</p> <p>The flow unit's options are the same As those in Menu 31.</p> <p>Press Enter to change the displayed Value.</p>	<div style="border: 1px solid black; padding: 5px;"> M56 CL 20mA Output 2000m3/h </div>
M57	<p>CL Checkup</p> <p>Press ENTER When Ready.</p> <p>It is necessary to re-calibrate the CL output according user's actual Output, the method is similar with M53.</p> <p>User can check up 0MA, 4 MA, 8MA, ...20MA etc. output.</p>	<div style="border: 1px solid black; padding: 5px;"> M57 CL Checkup ENTER When Ready </div>
M58	CL Output display	
M60	<p>Setup the date and time of the meter.</p> <p>Press ENTER to change it if necessary.</p>	
Above is service options and CL output applications		
M61	<p>Display Version information and Electronic Serial Number (ESN) that are unique for each series CLAMP-ON 1100heat</p>	

	meter.	
M62	<p>RS232C communication setup</p> <p>Commonly, user should select “9600, None”</p> <p>9600 is baud rate, check bit is “None”.</p>	<div style="border: 1px solid black; padding: 5px; width: fit-content;"> M62 RS-232C Setup 9600, None </div>
M63	<p>Analog input temperature sensor range value for heat flow application, wiring terminals is Tin+, Tin-. Press ENTER and use key \wedge or \vee to input value corresponding 4mA and 20mA</p>	
M64	<p>Analog input temperature sensor range value for heat flow application, wiring terminals is Tout+, Tout-. Press ENTER and use key \wedge or \vee to input value corresponding 4mA and 20mA</p>	
M65	<p>Setup the frequency range for the frequency output. The biggest range is 0Hz-9999Hz. Default value is 1-1001 Hz.</p>	
M66	<p>Setup the Low Frequency Output Corresponding Value of Flow Rate. This value correspond to the lowest Frequency value entered in M65.</p>	<div style="border: 1px solid black; padding: 5px; width: fit-content;"> M66 Low FO Flow Rate 0 m3/h </div>
M67	<p>Setup the High Frequency Output Corresponding Value of Flow Rate. This value correspond to the highest Frequency value entered in M65.</p> <p>Please see the *Note for wiring diagram.</p>	<div style="border: 1px solid black; padding: 5px; width: fit-content;"> M67 High FO Flow Rate 3000 m3/h </div>
M70	<p>LCD Backlit option. User can select “Always On”, Always Off” or “Lighting for” items, if select “Lighting for”, please entered a second value, it indicates how many seconds the backlight will be on.</p>	
M71	<p>LCD contrast control. The LCD will become darker when a small value is entered.</p>	
M72	<p>Working timer. It can be cleared by pressing ENTER key, and then select YES.</p>	
M73	<p>Alarm #1 Low Value</p> <p>Enter Lowest Flow Rate value that will trigger the Relay</p>	

	wiring terminal output Alarm.
M74	Alarm #1 High Value Enter Highest Flow Rate value that will trigger the Relay wiring terminal output Alarm.
M75	Not used
M76	Not used
M77	<p>Buzzer setup.</p> <p>If a proper input source is selected, the buzzer will beep when the trigger event occurs</p> <ol style="list-style-type: none"> 0. No Signal 1. Poor Signal 2. Not Ready --state error 3. Reverse Flow 4. Analog Output overflow 100% 5. Frequency Output overflow 120% 6. Alarm #1 7. Alarm #2 (not used) 8. Batch Control 9. Positive Int Pulse 10. Negative Int Pulse 11. Energy Pulse 12. ON/OFF via RS232 13. Fluid Changed –fluid sound speed changed 14. Key Stroke ON –ring when press key 15. Not using –close the buzzer
M78	OCT output Selection (Pulse output for flow rate)
M79	Relay Output Setup
M80	Flow Batch Control
M81	Setup Flow Batch Control Value
M82	<p>The history logger of net totalizer</p> <p>net totalizer of day</p> <p>net totalizer of month</p> <p>net totalizer of year</p>
M83	<p>Auto. Correction</p> <p>Auto gain the totalizer flow if system power off</p>

M84	Heat Flow Unit: kWh; GJ
M85	Temp. Selection: 0. From T1, T2 input 1. Fixed temperature difference
M86	Specific Heat Selection
M87	Heat Flow Totalizer
M88	Heat Flow Multiplier
M89	Reset Heat Flow Totalizer
M90	Display signal strength, signal quality, IMPORTANT When installing the transducers, Let Q Value at least ≥ 60 <div style="border: 1px solid black; padding: 5px; width: fit-content; margin-left: auto; margin-right: auto;"> M90 Strength + Quality S=00.0, 00.0 Q=00 </div>
M91	Displays the Time Ratio between the Measured Total Transit Time and the Calculated time. If the pipe parameters are entered correctly and the transducers are properly installed, the ratio value should be in the range of $100\pm 3\%$. Otherwise the entered parameters and the transducer installation should be checked. <div style="border: 1px solid black; padding: 5px; width: fit-content; margin-left: auto; margin-right: auto;"> M91 TOM/TOS*100 0.0000% </div>
M92	Displays the measured fluid sound speed. Normally this value should be approximately equal to the entered value in Menu 21 when M20 the fluid type select “ Other ”. If this value has an obvious difference with the actual fluid sound speed, pipe parameters entered and the transducer installation should be checked again. If Menu20, the fluid type doesn’t select “ Other ”, this window is no matter with user.
M-1	Calibrate T1 at 0°C, We have already done the calibration in our laboratory(the same for M-2, M-3, M-4), so customers do not need to calibrate. When the value has been changed or need to recalibrate, customers can calibrate the value yourselves.
M-2	Calibrate T1 at 200°C
M-3	Calibrate T2 at 0°C
M-4	Calibrate T2 at 200°C

Note: Some contents in window menu order are not displayed in new software version, it won't influence user to use CLAMP-ON 1100, just press or to scroll the menu window and view or setup necessary menu contents.

PART-5 ENERGY FUNCTION

5.1 INTRODUCTION

Series CLAMP-ON 1100 heat meter owns an in-built module for energy calculation. It can calculate the thermal enthalpy of the liquid of a certain temperature automatically. Accordingly we can calculate the heat flow and totalizer. Temperature signal is input by analog hardware T1, T2 which can only receive 4-20mA and 0-20mA current signal.

All above results can be transferred to host computer through a communication protocol of the portable Heat Meter. In this case, CLAMP-ON 1100heat meter works as data monitoring network RTU, greatly decrease the complexity, cost and enhancing the reliability of the hardware of devices.

5.2 WIRING CONNECTION

Analog input can be connected to four 4-20mA temperature signal from outside. When calculating energy, T1 connects to inlet sensor and T2 to outlet sensor.

Menu06 displays the corresponding temperature.

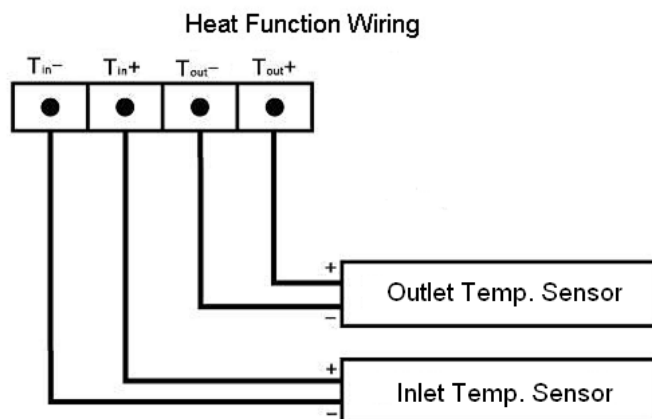

Clamp-on PT1000

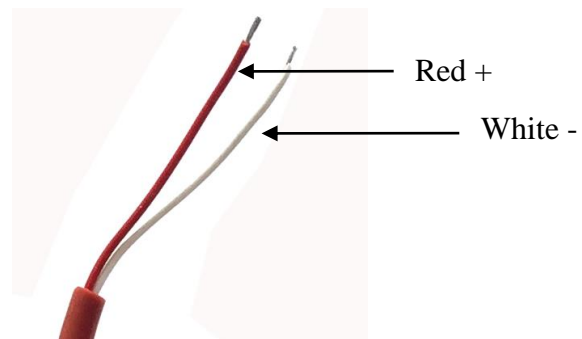

PT1000 wiring connection

5.3 ENERGY CALCULATION

We have two Methods to calculate energy:

Method 1): $\text{Energy} = \text{Flow} \times \text{Temp. Difference} \times \text{heat capacity}$ (Where: Temp. Difference refers to the temperature difference between T_{in} and T_{out} ; heat capacity is in Menu 86, commonly it is $-1.16309 \text{KWh/m}^3\text{°C}$)

Method 2): $\text{Energy} = \text{Flow} \times (\text{thermal enthalpy at } T_1 \text{ temp.} - \text{thermal enthalpy at } T_2 \text{ temp.})$
This thermal enthalpy is automatically calculated by heat meter according to international standard.

Menu 84 Energy unit selection, KWh, KC optional.

Menu 85 Temperature Signal Origin Selection

0. From T_1 , T_2 input

1. Fixed temperature difference

Menu 86 Select the specific heat to display according to international standard or fixed value.

Select >0.GB for energy unit KC

Select >1. Fix Spec. Heat for energy unit KWh

Menu 87 Open or Close energy flow totalizer.

Menu 88 Totalizer multiplication factor selection

Menu 89 Reset Zero energy totalizer.

If the liquid temperature goes steady, use can remove the temperature sensor and calculate the energy according to the estimated temperature difference.

5.4 TEMPERATURE RANGE

Temperature range is defined in Menu63 and Menu64. The first digit in Menu refers to the analog signal value input at 4mA current, the second digit refers to the analog signal value input at 20mA current.

For example, at the condition that when temperature sensor outputs 4mA current, temperature is 0°C , and outputs 20mA current, temperature is 200°C , this temperature sensor is connected to T_1 , and user needs to input 0, 200 in Menu63. User can check the displayed temperature value in Menu 06.

PART-6 TEMPERATURE SENSOR INSTALLATION

6.1 PT1000 TEMPERATURE SENSOR

CLAMP-ON 1100 heat meter utilizes two PT1000 temperature sensors, and the temperature sensors are matching. Temperature sensor cable is provided by manufacturer, and the standard length is 5m.

For measurement accuracy, test security, convenient maintenance, and not affect equipment operation and production operation, we should pay attention to the following before installation:

1. Should be rationally choose installation position, avoid the valve, elbow and equipment installed with thermal resistance.
2. For measuring the fluid temperature of pipe center, generally the measurement terminal is inserted into the pipe in the center.
3. Water supply temperature sensor (high temperature point) must be installed in flow transducer downstream side, and is apart from the downstream flow transducer 5DN.
The return water temperature sensor (low temperature point) should choose the position where is in recent from water supply temperature sensor.

6.2 TEMPERATURE SENSOR INSTALATION

(a) 6.2.1 CLAMP-ON TEMPERATURE SENSOR

When determining the installation position of temperature sensor, we should pay attention to the pipeline surface. Pipeline surface must be clean before installing temperature sensor, then use belts to fix temperature sensor.

(b) 6.2.2 INSERTION TEMPERATURE SENSOR

The insertion temperature sensor is directly contact with measured fluid, so its accuracy is higher. We have two methods to install insertion temperature sensor.

1. Installing by ball valve

For weldable pipe material, weld ball valve on pipe directly. For unweldable pipe material, first welding a hoop (Usually material is carbon steel) on pipe, then welding ball valve on hoop.

After welding ball valve, drill a suitable hole. Drill into the pipe wall in accordance with the instructions supplied with the drilling machine, at first, please select the slow tap position to drill hole, then select fast tap position.

After drilling a hole, plug in the insertion temperature sensor, adjust the insertion depth, then fix it.

2. Installing on pipe directly

Drill a suitable hole on pipe directly, plug in the insertion temperature sensor, adjust the insertion depth, and then fix it.

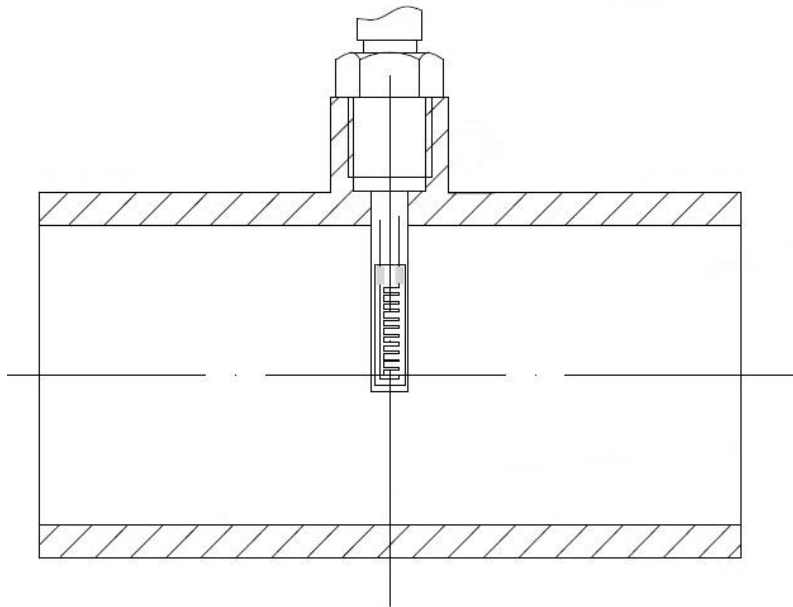

Note: The cables of two temperature sensor must be the same length.

PART-7 HOW TO USE MENU FUNCTIONS

5.1 HOW TO JUDGE WHETHER THE INSTRUMENT WORKS PROPERLY

Generally speaking, when ‘R’ is displayed in the lowest right corner of LCD display, the instrument is working properly.

If an ‘H’ flashes on that place, there could be poor signal received. Please refer to the chapters on diagnosis.

If an ‘I’ is displayed, it means that there is no signal detected.

If a ‘J’ is displayed, it means that the hardware of this instrument could be out of order. Refer to the chapter on diagnosis.

5.2 HOW TO JUDGE THE LIQUID FLOWING DIRECTION

Make sure that the instrument works properly

Check the flow rate for the indication. If the displayed value is positive, the direction of the flow will be from the UP transducer to the Down transducer; if the displayed value is negative, the direction will be from the Down transducer to the UP transducers;

Check the flow rate, if the display value is “+”, will it is positive. If the display value is “-”, It is negative.

5.3 HOW TO RESET THE DEFAULT SETUPS

Use M37, it has another function to recover the default setups. When the ‘selection’ message is displayed. Press the dot key first, then press key ◀ then press ENTER, meter will erase all the parameters entered by the user and setup the meter with default values.

5.4 HOW TO STABILIZE THE FLOW

The damping acts as a filter for a stable reading. If ‘0’ is entered in window M40, that means there is no damping. A bigger number brings a more stable effect. But bigger damping numbers will prevent the instrument from acting quickly. Numbers 0 to 10 are commonly used for the damping value.

5.5 HOW TO USE THE ZERO-CUTOFF FUNCTION

The number displayed in window M41 is called the low-cutoff value. The flow meter will replace these flow rate values that are absolutely less than the low-cutoff value with '0'. This means the flow meter will avoid any invalid accumulation when the actual flow is below the zero-cutoff value.

The low-cutoff value does not affect the flow measurement when the actual flow is absolutely greater than the low-cutoff value.

5.6 HOW TO SETUP A ZERO POINT CALIBRATION

It is necessary to establish the true zero flow condition and program that set point into the instrument. If the zero set point is not at true zero flow, a measurement difference may occur. Because every flow meter installation is slightly different and sound waves can travel in slightly different ways through these various installations, a provision is made in this entry to establish "True Zero" flow – SETUP ZERO.

There exists a 'Zero Point' with certain installation which means the flow meter will display a non-zero value when the flow is absolutely stopped. In this case, setting a zero point with the function in window M42 will bring a more accurate measurement result. When do a calibration test, it is also very important.

Make sure that the pipe is full of liquid and the flow is absolutely stopped - securely close any valves and allow time for any settling to occur. Then run the function in window M42 by press the **MENU** **4** **2** keys, then press **ENTER** key and wait until the counter readings displayed in the lower right corner of the screen goes to "00"; thus, the zero set is completed and the instrument indicates the results automatically through Window No.01. Repeat zero set calibration if it still needs to be minimized, i.e. the velocity reading is still high.

5.7 HOW TO USE SCALE FACTOR

Scale factor refers to the ratio between "actual value" and "reading value". For instance, when the measurement is 2.00, and it is indicated as 1.98 on the instrument, the scale factor reading is 2/1.98. This means that the best scale factor constant is 1. However, it is difficult to keep the scale factor as "1" on the instrument especially in batch control operations. The difference is called "consistency". High quality products always require high consistency.

The scale factor default is "1" or a factory calibration value (see the calibration data sheet for every meter) for each instrument prior to shipment from the factory. The scale factor

entered must be one that results from actual calibration. Re-calibration or change the Scale factor may be necessary on different pipe lines or different applications in order to obtain better accuracy.

5.8 HOW TO USE THE OPERATION LOCKER

The system locker provides a means of preventing inadvertent configuration changes or totalizer resets. Using the menu 48 when the system is locked, menu window browsing can be done without affecting any change, but any modifications are prohibited.

The system can be locked with a one 1 to 8 digit password.

If the password is forgotten, please contact the factory for a common password.

5.9 HOW TO USE THE 4~20M A OUTPUT

Refer to Menu 53, 54, 55, 56, 57, 58. Possessing a current loop output exceeding an accuracy of 0.1%, the CLAMP-ON 1100 is programmable and configurable with multiple output modules such as 4~20mA or 0~20mA. Select in Window M54. For details, please refer to Part 4 – Windows Display Explanations. In Window M55, enter a 4mA flow value. Enter the 20mA flow value in Window M56. For instance, if the flow range in a specific pipe is 0~1000m³/h, enter 0 in Window M55 and 1000 in Window M56. If the flow ranges from -1000~0~2000m³/h, configure the 20~4~20mA module by selecting Window M54 when flow direction is not an issue. Enter -1000 in Window M55 and 2000 in Window M56. When flow direction is an issue, module 0~4~20mA is available. When the flow direction displays as negative, the current output is in range of 0~4mA, whereas the 4~20mA is for the positive direction. The output module options are displayed in Window M54. Enter “-1000” in Window M55 and 2000 in Window M56. Calibrating and testing the current loop is performed in Window M57. Complete the steps as follows: Press Menu, 5, 7, ENTER, move \wedge or \vee to display “0mA”, “4mA”, “8mA”, “16mA”, “20mA” readings, connect an ammeter to test the current loop output and calculate the difference. Calibrate it if the difference is within tolerance. Check the present current loop output in Window M58 as it changes along with change in flow.

5.10 HOW TO USE THE FLOW RATE FREQUENCY OUTPUT

CLAMP-ON 1100 provides a frequency output transmitter function. The high or low frequency output displayed indicates the high or low flow rate reading. The user can reset the frequency output as well as flow rate per his requirements For instance: if a pipe flow range is 0~2000m³/h, the relative frequency output required is 10~1000Hz, and the configuration is as follows:

In Window M66 (low limit frequency output flow value), input 0;

In Window M67 (high limit frequency output flow value), input 2000;

In Window M65 (Select frequency range), Press ENTER, input Low FO frequency 10, Press \vee , input 1000.

There is no output circuit specially assigned to frequency output. It need to be powered through OCT, and select item FO in Window M78 (item “FO”—Frequency output.).

5.11 HOW TO USE RELAY OUTPUT

Relay output **only for Totalizer Output or Relay Alarm Output.**

Once the transmitter is powered on, the “OCT +, -” output is normally Open state.

When the relay is used for totalizer output, connect terminal “OCT + -“, select the corresponding totalizer in Menu 79, and setup the minimum display totalizer increments in Menu 33. Every time the totalizer increases a value set in M33, the relay closed one time.

When the relay is used for alarm output, connect terminal “OCT + -“, select the corresponding item in Menu 79, it can be used for several alarm condition. For example, select “Alarm #1”, set “Alarm #1 Low Value” in Menu 73, and set “Alarm #1 High Value” in Menu 74. When the flow is between the low value and high value, the relay is open state, and when the flow is lower than “Low Value”, or higher than “High Value”, the relay is closed state.

5.12 HOW TO SET THE DATE AND TIMER

Use the windowM60, press ENTER key and then input the new data and the new time. Press the ENTER key to confirm.

5.13 ON/OFF NET TOTALIZER

Window M34 is available to turn net totalizer on and off net. Window No.35 is available to turn the positive totalizer on and off, while Window No.36 is for the negative totalizer. Select “On” to activate the totalizer and “Off” to de-activate the totalizer.

5.14 UNITS OPTIONS

Measurement units options, Metric or English, select M30, Press ENTER, and scroll the \wedge or \vee to select units; Flow rate units, Select M31, Press ENTER, and scroll the \wedge or \vee to select units. Details please refer to Part 4, Windows Display Explanations.

5.15 LCD BACKLIT OPT IONS

Adjustment the backlighting in window M70, press MENU, 7 , 0 , then press ENTER, then use \wedge or \vee to scroll the menu, to select backlit options.

5.16 USE MENU WINDOWS FOR TRANSDUCER MOUNTING INSPECTION

5.16.1 Signal Strength

Signal strength (displayed in Window M90) indicates a detected strength of the signal both from upstream and downstream directions. The relevant signal strength is indicated by numbers from 00.0~99.9 in the CLAMP-ON 1100. 00.0 represents no signal detected while 99.9 represent maximum signal strength.

Normally, the stronger the signal strength detected, the instrument will work more reliably, as well as the more stable the measurement value obtained.

Adjust the transducer to the best position and check to ensure that enough sonic coupling compounds is applied adequately during installation in order to obtain the maximum signal strength. System normally requires signal strength over 60.0, which is detected from both upstream and downstream directions. If the signal strength detected is too low, the transducer installation position and the transducer mounting spacing should be re-adjusted and the pipe should be re-inspected. If necessary, change the mounting to the Z method.

5.16.2 Signal Quality (Q value)

Q value is short for Signal Quality (displayed in Window M90). It indicates the level of the signal detected. In the CLAMP-ON 1100, Q value is indicated by numbers from 00~99. 00 represents the minimum signal detected while 99 represent the maximum. Normally, the transducer position should be adjusted repeatedly and coupling compound application should be checked frequently until the signal quality detected is as strong as possible.

5.16.3 Total Time and Delta Time

“Total Time and Delta Time”, which displays in Window No.93, indicates the condition of the installation. The measurement calculations in the flow meter are based upon these two parameters. Therefore, when “Delta Time” fluctuates widely, the flow and velocities fluctuate accordingly. This means that the signal quality detected is too poor. It may be the resulted of poor pipe-installation conditions, inadequate transducer installation or incorrect parameter input. Generally, “Delta Time” fluctuation should be less than $\pm 20\%$. Only when the pipe diameter is too small or velocity is too low can the fluctuation be wider.

5.16.4 Transit Time Ratio (M91)

Transit Time Ratio indicates if the transducer mounting spacing is accurate. The normal transit time ratio should be $100\pm 3\%$ if the installation is proper. Check it in Window M91. If the transit time ratio is over $100\pm 3\%$, it is necessary to check (1) if the parameters (pipe outside diameter, wall thickness, pipe material, liner, etc.) have been entered correctly, (2) if the transducer mounting spacing is accordance with the display in Window M25, (3) if the transducer is mounted at the pipe’s centerline on the same diameter, or (4) if the scale is too thick or the pipe mounting is distorted in shape, etc.

5.16.5 Warnings

1. Pipe parameters entered must be RIGHT; otherwise the flow meter will not work

properly.

2. During the installation, apply enough coupling compounds in order to stick the transducer onto the pipe wall. While checking the signal strength and Q value, move the transducer slowly around the mounting site until the strongest signal and maximum Q value can be obtained. Make sure that the larger the pipe diameter, the more the transducer should be moved. Check to be sure the mounting spacing is accordance with the display in Window M25 and the transducer is mounted at the pipe's centerline on the same diameter. Pay special attention to those pipes that formed by steel rolls (pipe with seams), since such pipe is always irregular. If the signal strength is always displayed as 0.00, that means there is no signal detected. Thus, it is necessary to check that the parameters (including all the pipe parameters) have been entered accurately. Check to be sure the transducer mounting method has been selected properly, the pipe is not worn-out, and the liner is not too thick. Make sure there is indeed fluid in the pipe or the transducer is not very close to a valve or elbow, and there are not too many air bubbles in the fluid, etc. With the exception of these reasons, if there is still no signal detected, the measurement site has to be changed.

3 Make sure that the flow meter is able to run properly with high reliability. The stronger the signal strength displayed, the higher the Q value reached. The longer the flow meter runs accurately, the higher the reliability of the flow rates displayed. If there is interference from ambient electromagnetic waves or the signal detected is too poor, the flow value displayed is not reliable; consequently, the capability for reliable operation is reduced.

4 After the installation is complete, power on the instrument and check the result accordingly.

PART-8 TROUBLESHOOTING AND FAQ

6.1 TROUBLESHOOTING

The CLAMP-ON 1100 ultrasonic flow meter has advanced self-diagnostics functions and displays any errors in the upper right corner of the LCD via definite codes in a date/time order. Hardware error diagnostics are usually performed upon each power on. Some errors can be detected during normal operation. Undetectable errors caused by incorrect settings and unsuitable measurement conditions can be displayed accordingly. This function helps to detect the errors and determine causes quickly; thus, problems can be solved in a timely manner according to the solutions listed in the following tables.

Errors displayed in the CLAMP-ON 1100 are divided into two categories: Table 1 is for errors displayed during self-diagnostics upon power on. “* F” may be displayed on the upper left corner of the screen after entering the measuring mode. When this occurs, it is necessary to power on for self-diagnostics once again to detect and solve possible errors using the table below. If a problem still exists, please contact the factory or the factory’s local representative for assistance.

Table 2 applies when errors caused by incorrect settings and signals are detected and are announced by error codes displayed in Window M07.

Table 1. Self-diagnoses and error solutions (upon power on)

LCD Display	Cause	Solution
Rom Parity Error	* System ROM illegal or error	* Contact the factory
Stored Data Error	* System stored data block error	* Power on again or contact the factory
SCPU Fatal Error!	* SCPU circuit fatal error	* Power on again or contact the factory
Timer Slow Error Timer Fast Error	* System clock error	* Contact the factory
CPU or IRQ Error	* CPU or IRQ problem	* Power on again
System RAM Error	* System RAM questionable	* Power on again or contact the factory
Time or Bat Error	* System date time chip error	* Power on again or contact the factory
No Display, Erratic or Abnormal Operation	* Bad wiring connection	* Check wiring connections
Stroke Key -No Response	*Keypad locked or bad plug connection	* Enter the unlock password if the keypad is locked

Table 2. Error codes and solutions (during operation)

Code	M08 Display	Cause	Solution
*R	System Normal	* System normal	No errors
*J	SCPU Fatal Error	* Hardware defect	* Contact the factory
*I	Signal Not Detected	*Signal not detected. *Spacing is not correct between the transducers or not enough coupling compound applied to face of transducers. * Transducers installed improperly. * Scale is too thick. * New pipe liner.	* Attach transducer to the pipe and tighten it securely. Apply a plenty of coupling compound on transducer and pipe wall. * Remove any rust, scale, or loose paint from the pipe surface. Clean it with a file. * Check the initial parameter settings. * Remove the scale or change the scaled pipe section. Normally, it is possible to change a measurement location. The instrument may run properly at a new site with less scale. * Wait until liners solidified and saturated.
*H	Low Signal Strength	* Low signal strength. * Cause refers to above-mentioned reasons.	* Solution refers to above-mentioned solutions.
*H	Poor Signal Quality	* Poor signal quality * All reasons are included in the above-mentioned causes.	* Solution refers to above-mentioned solutions.
*E	Current Loop over 20mA (No influence normally. Ignore it if no current output is being used.)	* 4-20mA current loop over 120%. * Improper settings to current loop output.	* Check settings (refer to Window M56) and confirm if actual flow is too high.

*Q	Frequency output over set value No influence normally. Ignore it if no frequency output is being used.	* Frequency output over 120%. * Improper settings to frequency output or actual flow are too high.	* Check settings (refer to Window M66-M69) and confirm if the actual flow is too high.
*F	Refer to Table 1.	* Error in self-diagnoses during power on. * Permanent hardware error.	* Power on again; resolve it by the method listed in Table 1. If it is still a problem, contact the factory. * Contact the factory.

6.2 FREQUENTLY ASKED QUESTIONS AND ANSWERS

Q: New pipe, high quality material, and all installation requirements met: why still no signal detected?

A: Check pipe parameter settings, installation method and wiring connections. Confirm if the coupling compound is applied adequately, the pipe is full of liquid, transducer spacing agrees with the screen readings and the transducers are installed in the right direction.

Q: Old pipe with heavy scale inside, no signal or poor signal detected: how can it be resolved?

A: Check if the pipe is full of fluid. Try the Z method for transducer installation (If the pipe is too close to a wall, or it is necessary to install the transducers on a vertical or inclined pipe with flow upwards instead of on a horizontal pipe). Carefully select a good pipe section and fully clean it, apply a wide band of coupling compound on each transducer surface (bottom) and install the transducer properly. Slowly and slightly move each transducer with respect to each other around the installation point until the maximum signal is detected. Be careful that the new installation location is free of scale inside the pipe and that the pipe is concentric (not distorted) so that the sound waves do not bounce outside of the proposed area. For pipe with thick scale inside or outside, try to clean the scale off, if it is accessible from the inside. (Note: Sometimes this method might not work and sound wave transmission is not possible because of the a layer of scale between the transducers and pipe inside wall) .

Q: Why is the CL output abnormal?

A: Check to see if the desired current output mode is set in Window M54. Check to see if the maximum and minimum current values are set properly in Windows M55 and M56. Re-calibrate CL and verify it in Window M53.

Q: Why is the flow rate still displayed as zero while there is fluid obviously inside the pipe and a symbol of “R” displayed on the screen?

A: Check to see if “Set Zero” was carried out with fluid flowing inside the pipe (Refer to

Window M42) . If it is confirmed, recover the factory default in Window M43.

Q: With a poor measurement site environment in the plant and the voltage and power supplies fluctuating widely, is the instrument really able to keep running 24 hours a day repeatedly without stopping and last for several years under such conditions?

A: CLAMP-ON 1100 is designed to work with high reliability under such conditions. It is provided with an intelligent signal conditioning circuit and internal correction circuitry. It will work under strong interference conditions and is able to adjust itself with strong or weak sound waves. It will work in a wide band of voltage: 90-260VAC or 8V~28V DC voltage.

Q: Why is the pipe not full of liquid or no flow in pipe, but still displays an unstable or wrong reading?

A: Pipe must be full of liquid, if not, ENTER the menu window M29, setup a EMPTY PIPE

Q VALUE less than normal Q value (pipe is full of liquid), cut off abnormal reading,

CLAMP-ON 1100 will display Zero reading.

PART-9 WARRANTY AND SERVICE

7.1 WARRANTY

The manufacturer provides one year warranty on all products, free of charge, but the users should be responsible for the one-way transportation fee from the customer to the factory.

7.2 SERVICE

The manufacturer provides instrument installation for our customers, and the charges will be made according the cost.

- (1) For any hardware failure of the instrument, we recommend that our customers send back the instrument to our factory for service, due to the fact that the instrument is made of microprocessors and it will be difficult to perform field maintenance. Before sending back the instrument, please try to contact the factory first to make sure what the problem is.
- (2) For other operational problems, please contact our local distributor by telephone, fax or email. In most cases, the problem could be solved immediately.

APPENDIX 1 INSERTION TRANSDUCER INSTALLATION

Overview

Insertion transducers can be installed into metal pipelines via an isolation ball valve (installation into pipelines of plastic or other materials may require an optional coupling; If the pipe material is cement, please consult factory to use special lengthen insertion transducer, furthermore, use special cement borer). The maximum pipe diameter in which insertion transducers can be installed is DN6000mm. Sensor cable length (10m standard) normally can be extended to as long as 300m. Follow the procedure below to install insertion transducers, the pipe size should not be smaller than DN50mm).

A, MENU CONFIGURATION

Refer to Part 2 and Part3, the transmitter is the same as Clamp-on Ultrasonic Flow meter, entering configuration parameters (pipe O.D., Wall Thickness, liquids type, etc.), then calculate the Transducer Spacing (Menu 23, Transducer type is: **5. Plug-in Type B45**; Menu 24, Transducer Mounting is: **1. Z**, for the Insertion transducer, pipe line diameter $\geq 100\text{mm}$, **the transducer Mounting type is Z mode, less than 100mm, is V methods.**

B, INSTALLATION LOCATING

After entering the setup parameters, the CLAMP-ON 1100 will calculate the transducer spacing (Menu 25, For CLAMP-ON 1100, commonly, this distance= I.D. (Inside Diameter) – 9.113mm). The transducer spacing is distance between the centre points of two transducers.

Z method is the most commonly used mounting method for insertion-type ultrasonic flow meters, suitable for pipe diameters ranging from 100mm to 6000mm. Due to strong signal strength and high measurement accuracy, the Z method is preferable for pipe sections severely rusted or with too much scale formation on the inside wall. When installing the transducer using the Z method, be sure that the two transducers and the pipeline center axis are in the same plane, but never in the 6 or 12 o'clock positions.

Perform the following steps to install transducers using the Z mounting method:
Locate the reference mounting positions of 3 and 9 o'clock as shown in Fig. 1.

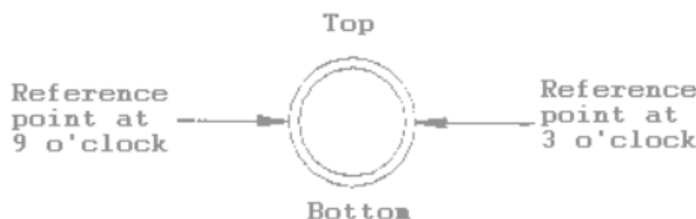

Fig.1 Reference Mounting Positions of 3 and 9 o'clock (Z Method)

1, Locating

By positioning paper, or positioning ropes, first identified point A and then confirmed C points

(A and C into 180° symmetric), extended C level again, determined to point B, $L = BC$

Step by step shown as below Fig.2 – 6

Fig.2 Prepare a rectangular paper or substitutes.

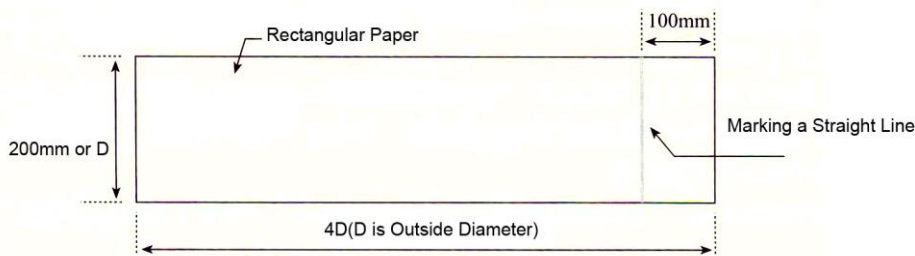

Fig. 2

Fig. 3 Wrap the paper around the pipeline with the folded end perpendicular to the length of the paper (Z Method).

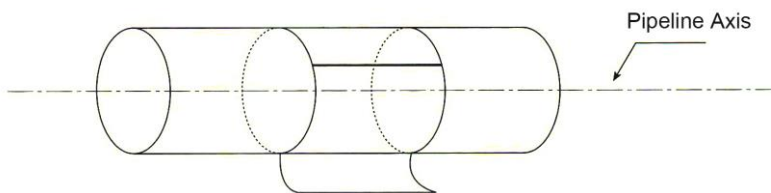

Fig. 3

Fig.4 Mark the overlapping line between the folded end and the other end of the paper, mark A point as shown.

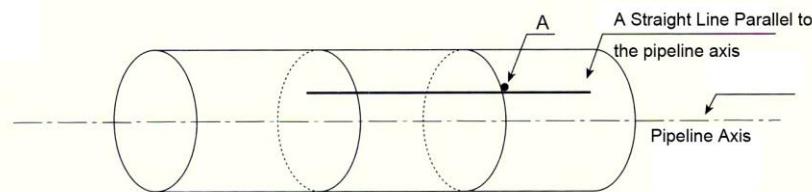

Fig. 4

Fig.5 Mark C point (A and C into 180° symmetric), extended C level again, determined to point B, $L = BC$, L is transducer spacing in Menu 25.

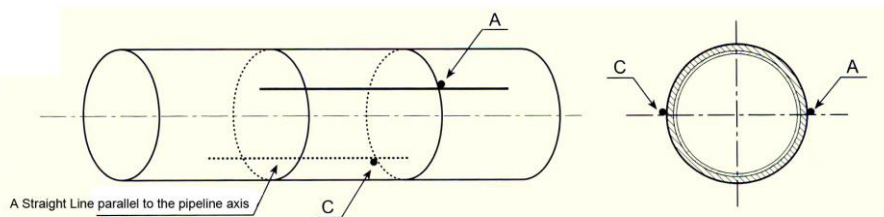

Fig. 5

Fig.6 Remove the positioning paper, prepare weld the ball valve bases on A and B point, **note that the center point of Ball Valve Base coincidences with the A, B points.**

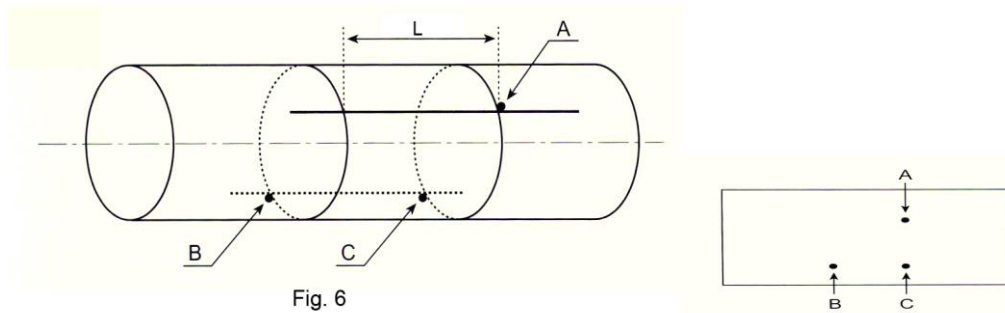

Fig. 6

C, DRILLING HOLES

After removing the auxiliary paper, draw a locating point and use it as the center to drill a hole of 19mm. Then, weld the transducer-mounting base vertically and install the transducer (Figure 7). Note that the inside central point of the transducer (on the other side of the cable connector) must coincide with the position point marked in Fig. 6.

After Welding the Ball Valve Base, mount the Ball Valve on base.

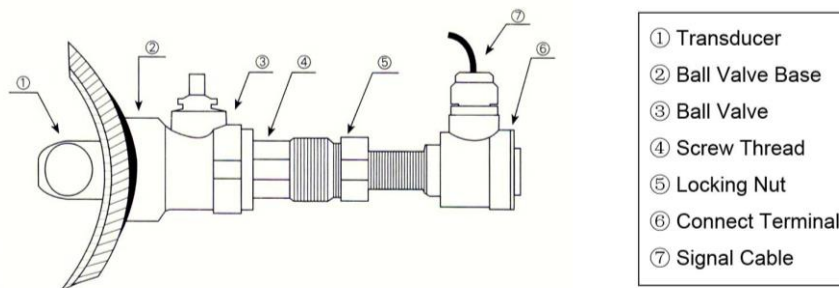

Fig.7 Construction Drawing of Insertion Transducer

Fig. 7 shows a diagram of the Insertion Transducer. The insertion transducer is attached to its mounting base (which is welded to the pipe section at the measurement point) via a ball valve. When the transducer is removed, pipe fluids can be contained by shutting off the ball valve. Therefore, installation and extraction of the transducer can be performed without relieving pipeline pressure. An O-ring seal and locking nut guarantee user safety while installing or operating the transducer.

If the pipe line is not weldable, please use special Pipe Hoop, shown as Figure 8, below

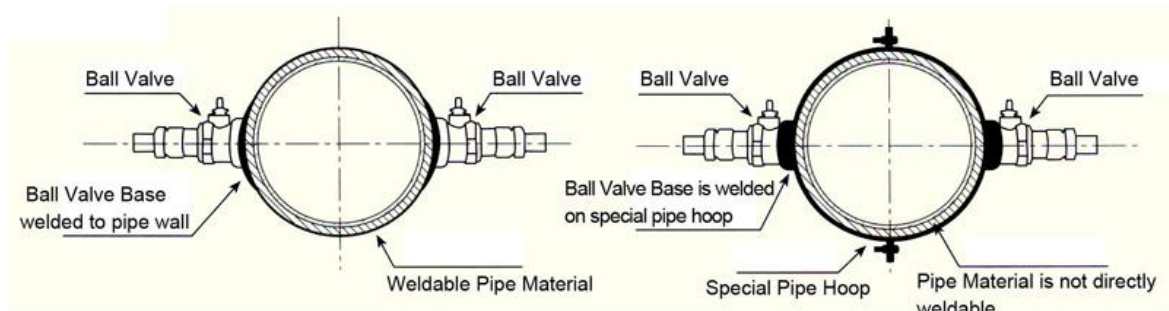

Figure 8

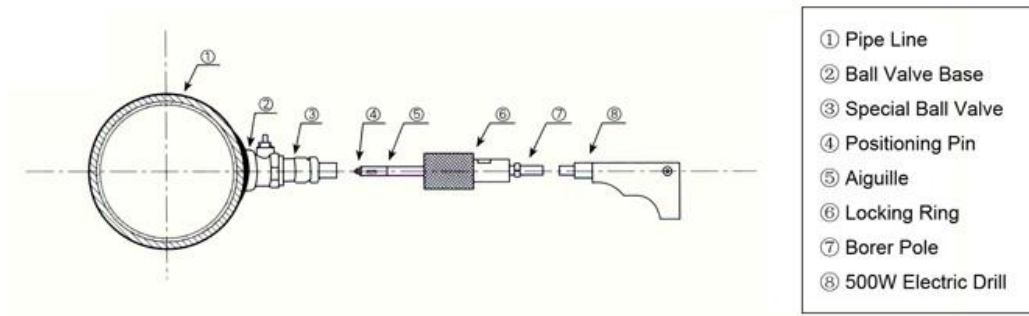

Figure 9 Drilling hole Diagram

After Welding the Ball Valve Base, mount the Ball Valve on base, note use PTFE belt for sealing.

Connecting the locking ring of borer to the thread of Ball Valve, tightening, open the Ball Valve, pushing the Borer Pole to outside of pipeline, connecting the 500W Electric Drill to the Borer Pole, tightening, power on, begin to drill hole. While drilling hole, keep the 500W Electric Drill relatively slow speed, do not too fast. After drilling hole finished, pull-out the Borer Pole, shut off the Ball Valve.

D, MOUNTING THE TRANSDUCERS

Procedures for installing insertion transducers follow: Fig.10 is mounting diagram

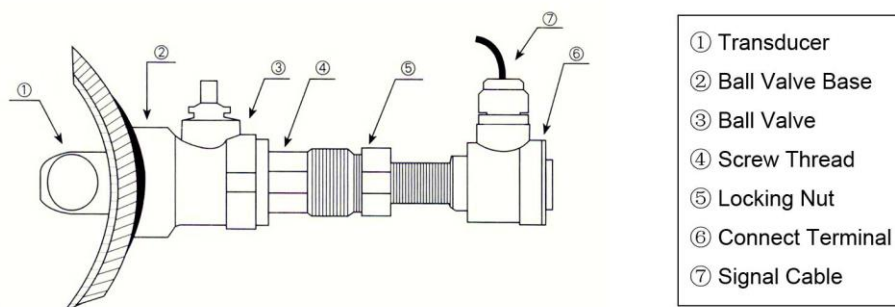

Fig. 10

Screwing the locking nut to bottom of transducer pole, insert the transducer into the Ball Valve, screw and then tighten the locking nut onto the ball valve.

Open the ball valve and insert the transducer into the pipe. At the same time, measure the Length L (See Fig.11) and make sure it complies with the following formula:

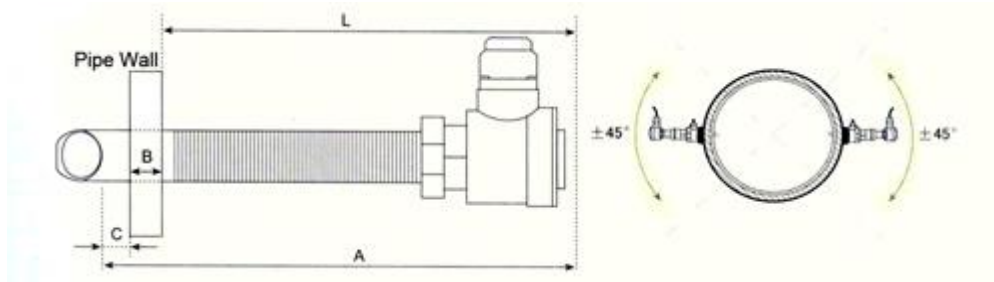

Fig. 11

$L = A - B$ (Let $C = 0$)

In this formula: L---Mounting height (mm)

A---Transducer length (mm)

B---Pipe wall thickness (mm)

As shown Fig.11 right, the cable holes of two transducers must be in same direction.

Important: For horizontal pipelines, transducers must be fixed on the sides of the pipe (i.e. at the 3 and 9 o'clock position of the pipe) to prevent signal attenuation caused by sediment on the bottom of the pipe or air bubbles and air pockets in the top of the pipe.

E, TRANSDUCER WIRING

SEE FIGURE12 Connect the transducer cables to the corresponding upstream/downstream terminal ends.

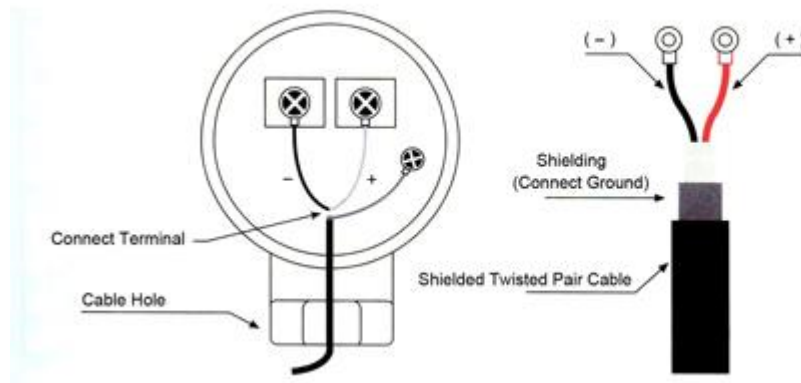

Fig. 12

In Fig. 12, if the colors of wirings are blue and brown, the blue wiring is connected to “+”, and the brown wiring is connected to “-”. If the colors of wirings are red and blue, the red wiring is connected to “+”, and the blue wiring is connected to “-”.

In order to keep the transducer waterproof, please screw tight the cable hole and wiring cover.

F, HOW TO OBTAIN GOOD SIGNAL STRENGTH AND SIGNAL QUALITY

After installing two transducers, please use Menu 90 and 91 to check the signal strength and signal quality, time ratio within the range of 97%-103%.

Screw one transducer or another transducer, let the value of Menu 90 at least > 60 .

The scale factor is used to modify the measurement results, factory default is 1.0 or other value depends on calibration. The user can enter a numerical value other than 1.0 according to re-calibration results.

APPENDIX 2 TRANSDUCER GUIDE RAIL INSTALLATION

Introduction

The mounting frame is designed for clamp-on transducer installation, it make the installation simple, allocation precise, fixation stable, and it also can meet to multiple transducer mounting methods.

Preparation

1. Before you attach the transducers you should first ensure that the proposed location satisfies the distance requirements as **Table 2.1**, otherwise the resulting accuracy of the flow readings may be affected.
2. Prepare the pipe by degreasing it and removing any loose material or flaking paint in order to obtain the best possible surface. A smooth contact between pipe surface and the face of the transducers is an important factor in achieving a good ultrasound signal strength and therefore maximum accuracy.
3. Parts prepare



Installation steps

1. Installation Steps for V and W Transducer Mounting Method

When using V or W method to install transducers, install the two transducers on the same side of pipeline.

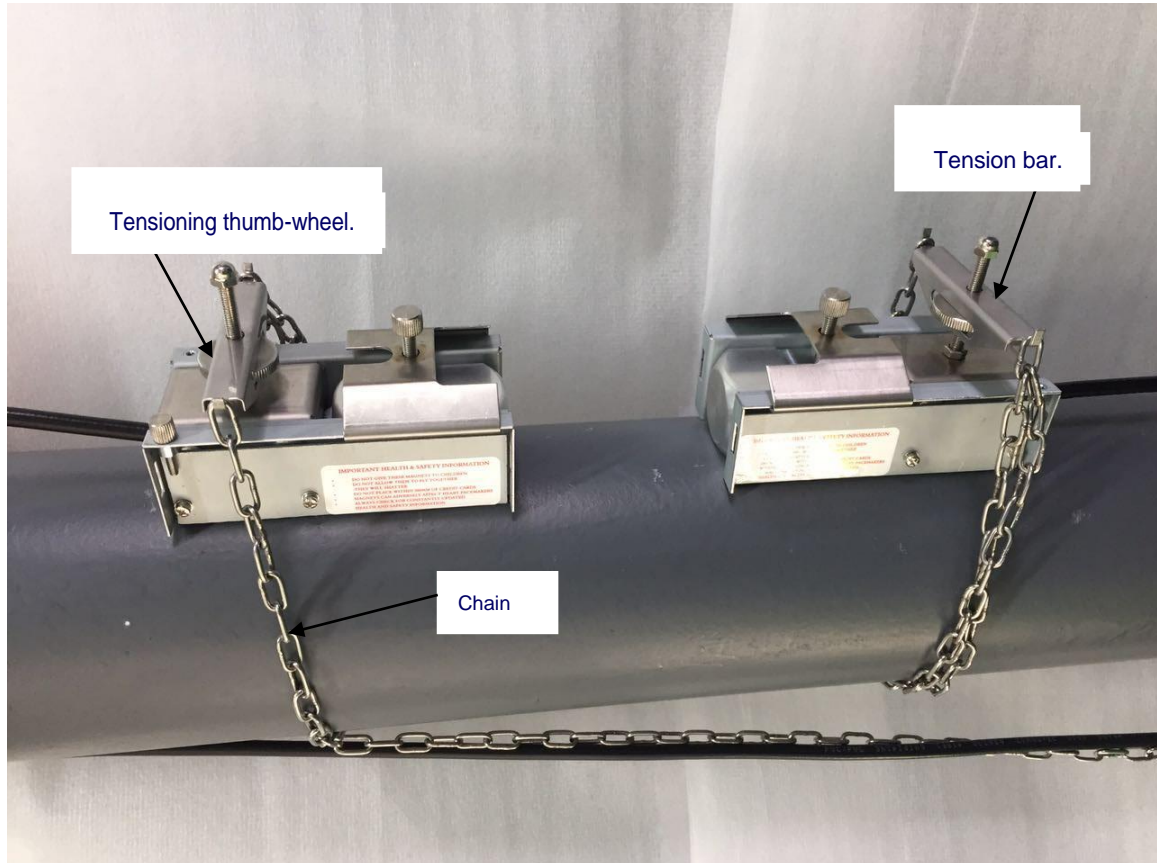

Step A : Fitting the guide rail

- 1) On each guide rail, attach one end of a securing chain to a hook on the **tensioning bar** wrap the chain around the pipe and then attach it to the hook on the other end of the **tensioning bar whilst** keeping the chain as tight as possible.
- 2) Rotate the complete guide rail assembly so that it is approximately 90° with respect to the top of the pipe. Then tighten the chain by turning the tensioning thumb-wheel on each guide block until the assembly is securely attached to the pipe.

Note: If you are unable to get sufficient tension on the chain to hold the assembly in place, fully slacken the tensioning thumb-wheel and shorten the effective length of the chain wrapped around the pipe by connecting the tensioning bar to the next link in the chain, then re-tension.

Step B : Fitting the transducers

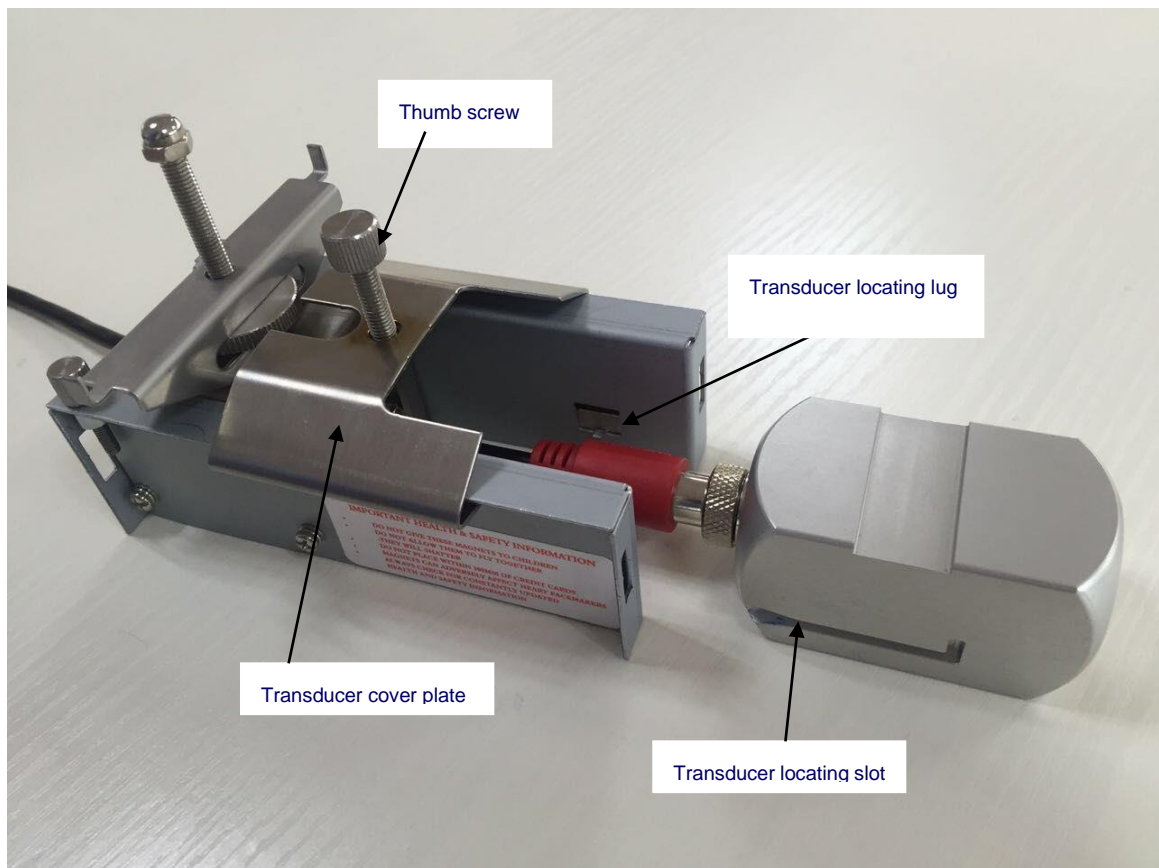

- 1). Slide the transducer **cover plate** fully towards the outside of the guide assembly to allow sufficient access to fit the transducer.
- 2). Clean the face of the transducer, removing all traces of dirt and grease.
- 3.) Lay on enough couplant on the transducer .
- 4). Connect the transducer cable. Fit the transducer into the guide block – ensuring the **lugs** on the sides of the guide block are correctly located into the **slots** on the sides of the transducer.
- 5). Slide the transducer **cover plate** over the top of the transducer and tighten the **thumbscrew** finger tight to secure the transducer in place.
- 6). Repeat the above steps for the second transducer.
- 7). Connect the transducers to the CLAMP-ON 1100 instrument using the transducer cables provided.

2 Installation Steps for Z and N Transducer Mounting Method

When using Z or N method to install transducers, install the two transducers respectively on the opposite sides of pipeline. Installation steps are same as for W and V transducer mounting method.

When finishing the installation, it will show as follow:

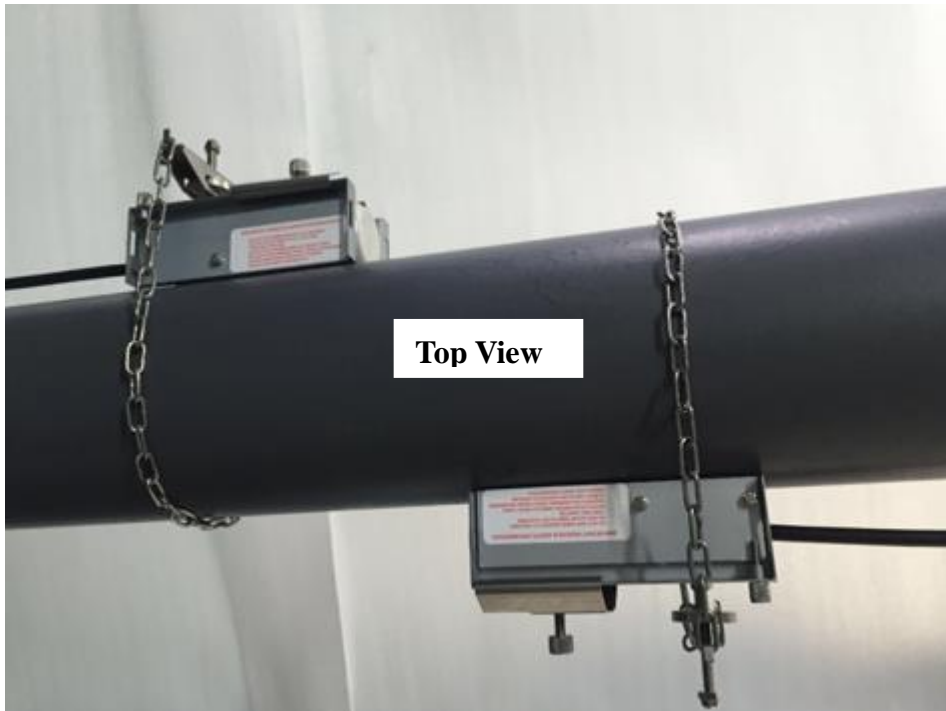

Notes:

1. Equally spread couplant on measuring side of transducer, and then put transducer into bracket from broadside, make sure pipeline and transducer have good coupling.
2. Do not over tighten to prevent couplant extrusion.
3. Ensure that the two brackets are on the same axial surface.

APPENDIX 3 FLUID CHARACTERISTIC (SOUND SPEED)

1. FLUID PROPERTIES

Fluid	Specific Gravity	Sound Speed		delta-v/degree C	Kinematic Viscosity	Absolute viscosity
	20 degrees C	m/s	ft/s	m/s/degree C	Centistokes	Centipoise
Acetate, Butyl		1270	4163.9			
Acetate, Ethyl	0.901	1085	3559.7	4.4	0.489	0.441
Acetate, Methyl	0.934	1211	3973.1		0.407	0.380
Acetate, Propyl		1280	4196.7			
Acetone	0.79	1174	3851.7	4.5	0.399	0.316
Alcohol	0.79	1207	3960.0	4.0	1.396	1.101
Alcohol, Butyl	0.83	1270	4163.9	3.3	3.239	2.688
Alcohol, Ethyl	0.83	1180	3868.9	4	1.396	1.159
Alcohol, Methyl	0.791	1120	3672.1	2.92	0.695	0.550
Alcohol, Propyl		1170	3836.1			
Alcohol, Propyl	0.78	1222	4009.2		2.549	1.988
Ammonia	0.77	1729	5672.6	6.7	0.292	0.225
Aniline	1.02	1639	5377.3	4.0	3.630	3.710
Benzene	0.88	1306	4284.8	4.7	0.711	0.625
Benzol, Ethyl	0.867	1338	4389.8		0.797	0.691
Bromine	2.93	889	2916.7	3.0	0.323	0.946
n-Butane	0.60	1085	3559.7	5.8		
Butyrate, Ethyl		1170	3836.1			
Carbon dioxide	1.10	839	2752.6	7.7	0.137	0.151
Carbon tetrachloride	1.60	926	3038.1	2.5	0.607	0.968
Chloro-benzene	1.11	1273	4176.5	3.6	0.722	0.799
Chloroform	1.49	979	3211.9	3.4	0.550	0.819
Diethyl ether	0.71	985	3231.6	4.9	0.311	0.222
Diethyl Ketone		1310	4295.1			
Diethylene glycol	1.12	1586	5203.4	2.4		
Ethanol	0.79	1207	3960.0	4.0	1.390	1.097
Ethyl alcohol	0.79	1207	3960.0	4.0	1.396	1.101
Ether	0.71	985	3231.6	4.9	0.311	0.222
Ethyl ether	0.71	985	3231.6	4.9	0.311	0.222
Ethylene glycol	1.11	1658	5439.6	2.1	17.208	19.153
Freon R12		774.2	2540			
Gasoline	0.7	1250	4098.4			
Glycerin	1.26	1904	6246.7	2.2	757.100	953.946
Glycol	1.11	1658	5439.6	2.1		
Isobutanol	0.81	1212	3976.4			
Iso-Butane		1219.8	4002			
Isopentane	0.62	980	3215.2	4.8	0.340	0.211
Isopropanol	0.79	1170	3838.6		2.718	2.134
Isopropyl alcohol	0.79	1170	3838.6		2.718	2.134
Kerosene	0.81	1324	4343.8	3.6		



Linalool		1400	4590.2			
Linseed Oil	.925-.939	1770	5803.3			
Methanol	0.79	1076	3530.2	2.92	0.695	0.550
Methyl alcohol	0.79	1076	3530.2	2.92	0.695	0.550
Methylene chloride	1.33	1070	3510.5	3.94	0.310	0.411
Methylethyl Ketone		1210	3967.2			
Motor Oil (SAE 20/30)	.88-.935	1487	4875.4			
Octane	0.70	1172	3845.1	4.14	0.730	0.513

Oil, Castor	0.97	1477	4845.8	3.6	0.670	0.649
Oil, Diesel	0.80	1250	4101			
Oil (Lubricating X200)		1530	5019.9			
Oil (Olive)	0.91	1431	4694.9	2.75	100.000	91.200
Oil (Peanut)	0.94	1458	4783.5			
Paraffin Oil		1420	4655.7			
Pentane	0.626	1020	3346.5		0.363	0.227
Petroleum	0.876	1290	4229.5			
1-Propanol	0.78	1222	4009.2			
Refrigerant 11	1.49	828.3	2717.5	3.56		
Refrigerant 12	1.52	774.1	2539.7	4.24		
Refrigerant 14	1.75	875.24	2871.5	6.61		
Refrigerant 21	1.43	891	2923.2	3.97		
Refrigerant 22	1.49	893.9	2932.7	4.79		
Refrigerant 113	1.56	783.7	2571.2	3.44		
Refrigerant 114	1.46	665.3	2182.7	3.73		
Refrigerant 115		656.4	2153.5	4.42		
Refrigerant C318	1.62	574	1883.2	3.88		
Silicone (30 cp)	0.99	990	3248		30.000	29.790
Toluene	0.87	1328	4357	4.27	0.644	0.558
Transformer Oil		1390	4557.4			
Trichlorethylene		1050	3442.6			
1,1,1-Trichloro- thane	1.33	985	3231.6		0.902	1.200
Turpentine	0.88	1255	4117.5		1.400	1.232
Water, distilled	0.996	1498	4914.7	-2.4	1.000	0.996
Water, heavy	1	1400	4593			
Water, sea	1.025	1531	5023	-2.4	1.000	1.025
Wood Alcohol	0.791	1076	3530.2	2.92	0.695	0.550
m-Xylene	0.868	1343	4406.2		0.749	0.650
o-Xylene	0.897	1331.5	4368.4	4.1	0.903	0.810
p-Xylene		1334	4376.8		0.662	

2. WATER SOUND SPEED

Water Sound Speed table (pressure: 1 bar)

Units: Sound Speed: m/s

Temperature °C	Sound Speed	Temperature °C	Sound Speed	Temperature °C	Sound Speed	Temperature °C	Sound Speed
0	1402.3	25	1496.6	50	1542.5	75	1555.1
1	1407.3	26	1499.2	51	1543.5	76	1555.0
2	1412.2	27	1501.8	52	1544.6	77	1554.9
3	1416.9	28	1504.3	53	1545.5	78	1554.8
4	1421.6	29	1506.7	54	1546.4	79	1554.6
5	1426.1	30	1509.0	55	1547.3	80	1554.4
6	1430.5	31	1511.3	56	1548.1	81	1554.2
7	1434.8	32	1513.5	57	1548.9	82	1553.9
8	1439.1	33	1515.7	58	1549.6	83	1553.6
9	1443.2	34	1517.7	59	1550.3	84	1553.2
10	1447.2	35	1519.7	60	1550.9	85	1552.8
11	1451.1	36	1521.7	61	1551.5	86	1552.4
12	1454.9	37	1523.5	62	1552.0	87	1552.0
13	1458.7	38	1525.3	63	1552.5	88	1551.5
14	1462.3	39	1527.1	64	1553.0	89	1551.0
15	1465.8	40	1528.8	65	1553.4	90	1550.4
16	1469.3	41	1530.4	66	1553.7	91	1549.8
17	1472.7	42	1532.0	67	1554.0	92	1549.2
18	1476.0	43	1533.5	68	1554.3	93	1548.5
19	1479.1	44	1534.9	69	1554.5	94	1547.5
20	1482.3	45	1536.3	70	1554.7	95	1547.1
21	1485.3	46	1537.7	71	1554.9	96	1546.3
22	1488.2	47	1538.9	72	1555.0	97	1545.6
23	1491.1	48	1540.2	73	1555.0	98	1544.7
24	1493.9	49	1541.3	74	1555.1	99	1543.9

3. PIPE MATERIAL SOUND SPEED TABLE

Pipe Material Sound Speed Table	Sound Speed(m/s)
Steel	3206
ABS	2286
Aluminum	3048
Brass	2270
Cast Iron	2460
Bronze	2270
Fiber Glass	3430
Glass	3276
Polyethylene	1950
PVC	2540

Liner Material	Sound Speed (m/s)
Teflon	1225
Titanium	3150
Cement	4190
Tar Epoxy	2540
Porcelain Enamel	2540
Glass	5970
Plastic	2280
Polyethylene	1600
PTFE	1450
Rubber	1600

APPENDIX 4 CLAMP-ON 1100 COMMUNICATIONS PROTOCOL

(For CLAMP-ON 1100V)

1. OVERVIEW

The CLAMP-ON 1100 has communication protocol. Its hardware directly supports a modem, a composition of flow data monitoring system that is economical, reliable and based on telephone line transmission. It can also be connected to a RS-485 or RS232C connectors based on jumpers on circuit board for user's option.

Two basic schemes can be chosen for networking, i.e. the analog current output method only using the CLAMP-ON 1100 or the RS232 communication method via serial port directly using the CLAMP-ON 1100. The former is suitable to replace dated instruments in old monitoring networks. The later is used in new monitoring network systems. It has advantages such as low hardware investment and reliable system operation.

When the serial port communication method is directly used to implement a monitoring network system, the address identification code (in window M46) of the flowmeter is used as network address code. Expanded command set with [W] is used as communication protocol. Thus analog current loop and OCT output of CLAMP-ON 1100 can be used to control the opening of a control valve. The relay output can be used to power-on/off other equipment. The analog input of the system can be used to input signals such as temperature. The system provides an RTU function for flow measurement.

RS-232C (0~15m) or RS-485(0~1000m) can be directly used for data transmission link for a short distance. Current loop, radio transmission and modem can be used in medium or long distance transmission.

When the CLAMP-ON 1100 is used in a network environment, various operations can be performed at the host device, except for programming of the address identification code, which needs to be done at the CLAMP-ON 1100 keyboard.

The command answer mode is used in data transmission, i.e. the host device issues commands and the flowmeter answers correspondingly.

Common/special flow/thermal data monitoring system developed by our company can be used for flow data collection. Based on characteristics of the CLAMP-ON 1100 flowmeter, the system makes full use of software and hardware designs with flowmeter features. The systems are simple, clear, low cost, and reliable in operation.

2. SERIAL PORT DEFINITIONS

Now CLAMP-ON 1100 communication output is RS485 or RS232C based on user's selection, please check the jumpers on circuit board; please refer to 3.3.4 RS232C or RS485 Wiring diagram.

RS232C connector is a 9 pins connector:

Pin 1, pin 4, pin 6, pin 7, pin 9: empty

Pin2: RXD receive

Pin3: TXD send

Pin5: Ground

Pin 8: +5V

3. RS232 COMMUNICATION PROTOCOL AND THE USE

The communication protocol format used by the CLAMP-ON 1100 ultrasonic flowmeter is: The host device requests the flowmeter to answer by sending a “command”. The baud rate of asynchronous communication (Primary station: computer system; Secondary station: ultrasonic flowmeter) is generally 9600bit/s. A single byte data format (10 bits): one start bit, one stop bit and 8 data bits. Check bit: none.

3. 1 Protocol Select

CLAMP-ON 1100 series flowmeter can't support protocol 0 and protocol 1 at the same time, in Menu +6, select protocol 0 or protocol 1.

When use RS232 for communication, select protocol 0 in menu +6.

3. 2 Basic commands

A data character string is used to express basic commands and a carriage return character is used to express the end of the command. The characteristic is that the length of data is flexible. Frequently used commands are as follows:

Table A-1 Communication commands

Command	Function	DATA format
DQD(cr) Note:0	Return Flow rate per day	±d.dddE±dd(cr) note:1
DQH(cr)	Return Flow rate per hour	±d.dddE±dd(cr)
DQM(cr)	Return Flow rate per minute	±d.dddE±dd(cr)
DQS(cr)	Return Flow rate per second	±d.dddE±dd(cr)
DV(cr)	Return Flow velocity	±d.dddE±dd(cr)
DI+(cr)	Return Positive totalizer	±dddE±d(cr) Note:2
DI-(cr)	Return Negative totalizer	±dddE±d(cr)
DIN(cr)	Return Net totalizer	±dddE±d(cr)
DIE(cr)	Return Positive Heat totalizer	±dddE±d(cr)
DID(cr)	Return Identification Number	ddd(cr) 5 bits in length
E(cr)	Return heat flow rate per second	±d.dddE±dd(cr)
DL(cr)	Return Signal Strength and quality	UP:dd.d,DN:dd.d,Q=dd(cr)
DS(cr)	Return percentage of Analog Output	±d.dddE±dd(cr)
DC(cr)	Return current error code	Note: 3
DA(cr)	Alarm signal of OCT or RELAY	TR:s,RL:s(cr) Note: 4

DT(cr)	Return current date and time	yy-mm-dd,hh:mm:ss(cr)
M@(cr)	Send a key value as if a key is pressed on CLAMP-ON 1100 panel	M@(cr) Note:5
LCD(cr)	Return currently displayed content on the current LCD display	
C1(cr)	OCT actuated	
C0(cr)	OCT not actuated	
R1(cr)	RELAY actuated	
R0(cr)	RELAY not actuated	
FOdddd(cr)	Let the FO output with a frequency in “dddd” value	Dodd(cr)(lf)
Aoa(cr)	Let the Analog Output with a value” a”	AOa(cr)(lf) Note:6
BA1(cr)	Return AI1 value (0~20mA)	±d.dddddE±dd(cr)(lf)
BA2(cr)	Return AI2 value (0~20mA)	±d.dddddE±dd(cr)(lf)
BA3(cr)	No used	±d.dddddE±dd(cr)(lf)
BA4(cr)	No used	±d.dddddE±dd(cr)(lf)
AI1(cr)	Return AI1 input value	±d.dddddE±dd(cr)(lf)
AI2(cr)	Return AI2 input value	±d.dddddE±dd(cr)(lf)
AI3(cr)	No used	±d.dddddE±dd(cr)(lf)
AI4(cr)	No used	±d.dddddE±dd(cr)(lf)
ESN(cr)	Return CLAMP-ON 1100 Electronic Serial Number(ESN)	dddddddt(cr)(lf) Note:7
N	Networking command Prefix of a single byte address	Note:8
W	Networking command Prefix of numeric string address	Note:8
P	Prefix of return command with check	
&	Function sign of command “add”	
RING(cr)(lf)	Modem request handshake command	ATA(CR)(lf)
OK(cr)	Modem answer signal	No output
	CLAMP-ON 1100 request	AT(CR)(lf)

	handshake signal	
--	------------------	--

Note:

- 0). (cr) express carriage return, “enter”, its ASCII value is 0DH.(lf) expresses line feed, its ASCII value is 0AH.
- 1). ”d” expresses 0~9 digit numbers, 0 value is expressed as +0.000000E+00
- 2). ”d” stands for 0~9 digit numbers , there is no decimal point in integral part before “E”.
- 3). The run status of the CLAMP-ON 1100 is expressed by 1~6 letters, for example “R”, “I”, ”H”
- 4). ”s” expresses ON or OFF or UD, For example “TR:ON,RL:ON” expresses that OCT and Relay are in actuated status;
“TR:UD,RL:UD” expresses OCT and Relay are not actuated.
- 5). “@” expresses key value, for example 30H,expresses“0” key; command “M4”is equivalent to pressing key“4”.
- 6). “a” expresses current value, the value range is 0~20, for example AO2.34567, AO0.2
- 7). Eight “ddddddd” express electronic serial number of the CLAMP-ON 1100. “t” expresses the type of the CLAMP-ON 1100.
- 8) If there are multiple CLAMP-ON 1100 flowmeters in a data network then the basic commands cannot be used alone. The prefix N or W must be added. Otherwise, multiple flowmeters will answer simultaneously, which will causes chaos in the system.

3.3 Function prefix and function sign

(1) Prefix P

The character P could add before every basic command. That means the transferred data has CRC verify. The method of counting the verified sum is gained by binary system addition.

For example: Command DI+(CR)(the relative binary system data is 44H, 49H, 2BH, 0DH) transferred data is +1234567E+0m3. (CR)(the relative binary system data is 2BH, 31H, 32H, 33H, 34H, 35H, 36H, 37H, 45H, 2BH, 30H, 6DH, 33H, 20H, 0DH, 0AH). And command PDI +(CR) transferred data is +1234567E+0m3!F7(CR), “!” means the character before it is the sum character, and the verified sum of the two bytes after it is (2BH+31H+32H +33H +34H +35H +36H +37H +45H +2BH + 30H +6DH +33H +20H = (2) F7H)

Note: there could be no data before “!”, and also may be blank character.

(2) Prefix W

Usage of Prefix W: W+ numeric string address code +basic command. Value range of the numeric string is 0~65535, except 13 (0DH carriage return), 10(0AH line feed), 42(2AH*) and 38(26H&). If the instantaneous velocity of No.12345 flowmeter is to be accessed, the

command W12345DV(CR) can use issued. Corresponding binary code is 57H, 31H, 32H, 33H, 34H, 35H, 44H, 56H and 0DH

(3) Function sign &

Function sign & can add up to 6 basic commands (Prefix P is allowed) together to form a compound command sent to the flowmeter together. The flowmeter will answer simultaneously. For example, if No.4321 flowmeter is requested to simultaneously return: 1) instantaneous flow(flow rate), 2) instantaneous velocity, 3) positive total flow, 4) total heat flow, 5) AI1 analogous input current value and, 6) AI2 analogous input current value with check, the following command is issued;

W4321PDQD&PDV&PDI+&PDIE&PBA1&PAI2(CR)

Simultaneously returned data are likely as follows;

+0.000000E+00m³/d!AC(CR)

+0.000000E+00m/s!88(CR)

+1234567E+0m³!F7(CR)

+0.000000E+0GJ!DA(CR)

+7.838879E+00mA!59

+3.911033E+01!8E(CR)

4. RS485 COMMUNICATION PROTOCOL AND THE USE

On mainboard, there are two Communications short-circuit piece, plug them to RS485 position.

The baud rate of asynchronous communication (Primary station: computer system; Secondary station: ultrasonic flowmeter) is generally 9600bit/s. A single byte data format (10 bits): one start bit, one stop bit and 8 data bits. Check bit: none.

Connect the “RS485 A B” two wiring terminals from mainboard to PC.

4.1 Protocol Select

CLAMP-ON 1100 series flowmeter can't support protocol 0 and protocol 1 at the same time, in Menu +6, select protocol 0 or protocol 1.

When use RS485 for communication, select protocol 1 in menu +6.

4.2 Communication commands

4.2.1 Asynchronous communication (Master station: computer system; Slave station: ultrasonic flow meter).

4.2.2 Baud rate is usually 9600 bit/s.

4.2.3 Single byte data format (10 bit)

4.1.3.1 start code: one bit.

4.1.3.2 stop code: one bit.

4.1.3.3 redundancy check code: no redundancy check.

4.1.3.4 digital codes: eight bits.

4.2.4 Gating Signal of Master station

4.2.4.1 Format of Gating Signal

*	Slave station NO.	Command from Master Station to Slave Station
①	②	③

①* is start code(ASCII code 2A).

②Slave station NO., 000-999(send 3 bytes ASCII code). 0 can't be omitted.

③Command From Master station to Slave station. There are 7 formats(0-6, send single byte ASCII code).

Command 0: obtain flow rate and total flow of Slave station.

Command 1: obtain flow velocity and total flow of Slave station.

Command 2: obtain positive and negative total flow of Slave station.

Command 3: obtain total working time of Slave station.

Command 4: obtain signal strength and signal quality of Slave station.

Command 5: clear total flow of Slave station

Command 6: clear total working time of Slave station

4.2.4.2 For example: * 189 0

It should be send: start code: 2A.

Slave station NO.: 31, 38, 39.

Command: 30.

4.2.5 Answer Signal of Slave Station

4.2.5.1 Answer Signal format for Master station Command 0

Command and symbol	flow rate	total flow	redundancy check bits
①	②	③	④

①Command and symbol: 2 bytes, the first byte is Master station command 0; the second byte is flow rate symbol(0 means positive and 1 means negative).

②Flow rate: 8 bytes (ASCII code) , the seventh and eighth bytes are fractional part.

③Total flow: 12 bytes (ASCII code) , the eleventh and twelfth bytes are fractional part.

④Redundancy check bits: 2 bytes (ASCII code) , it is the accumulative sum of former 22 bytes(with decimal additions accumulated) as redundancy check code in transmission process.

For example: Master station Command 0, flow rate symbol is positive, flow rate value is 367.89m³/h, total flow is 16745.78m³, it should send 30, 30, 30, 30, 30, 33, 36, 37, 38, 39, 30, 30, 30, 30, 30, 31, 36, 37, 34, 35, 37, 38, 33, 31.

Note: accumulative sum is 31(should send 33, 31).

4.2.5.2 Answer Signal format for Master station Command 1

Command and symbol	flow rate	total flow	redundancy check bits
①	②	③	④

①Command and symbol: 2 bytes, the first byte is Master station command 1; the

second byte is flow rate symbol(0 means positive and 1 means negative).

②flow rate: 8 bytes (ASCII code) , the fifth, sixth, seventh and eighth bytes are fractional part.

③ total flow: 12 bytes (ASCII code) , the eleventh and twelfth bytes are fractional part.

④ redundancy check bits: 2 bytes (ASCII code) , it is the accumulative sum of former 22 bytes(with decimal additions accumulated) as redundancy check code in transmission process.

For example: Master station Command 1, flow rate symbol is positive, flow velocity value is 3.6859m/s, total flow is 16745.78m³, it should send 31, 30, 30, 30, 30, 33, 36, 38, 35, 39, 30, 30, 30, 30, 30, 31, 36, 37, 34, 35, 37, 38, 33, 30.

Note: accumulative sum is 30(should send 33, 30).

4.2.5.3 Answer Signal format for Master station Command 2

Command and symbol	positive total flow	negative total flow	redundancy check bits
①	②	③	④

①Command and symbol: 2 bytes, the first byte is Master station command 2; the second byte is insignificant (random 0 or 1).

②Positive total flow: 12 bytes (ASCII code) , the eleventh and twelfth bytes are fractional part.

③Total flow: 12 bytes (ASCII code) , the eleventh and twelfth bytes are fractional part.

④Redundancy check bits: 2 bytes (ASCII code) , it is the accumulative sum of former 26 bytes(with decimal additions accumulated) as redundancy check code in transmission process.

For example: Master station Command 2, positive total flow is 14368.59m³, it should send 32, 30, 30, 30, 30, 30, 30, 31, 34, 33, 36, 38, 35, 39, 30, 30, 30, 30, 31, 36, 37, 34, 35, 37, 38, 32, 39.

Note: accumulative sum is 29(should send 32, 39).

4.2.5.4 Answer Signal format for Master station Command 3

Command and symbol	total working time	redundancy check bits
①	②	③

①Command and symbol: 2 bytes, the first byte is Master station command 3; the second byte is insignificant (random 0 or 1).

②Total working time: 8 bytes (ASCII code) , unit is minute.

③Redundancy check bits: 2 bytes (ASCII code) , it is the accumulative sum of former 10 bytes(with decimal additions accumulated) as redundancy check code in transmission process.

For example: Master station Command 2, total working time is 4368 minutes, it should send 33, 30, 30, 30, 30, 30, 34, 33, 36, 38, 32, 34.

Note: accumulative sum is 24(should send 32, 34).

4.2.5.5 Answer Signal format for Master station Command 4

Command and symbol	signal strength and signal quality	redundancy check bits
①	②	③

①Command and symbol: 2 bytes, the first byte is Master station command 4; the second byte is insignificant (random 0 or 1).

②Signal strength and signal quality: 8 bytes (ASCII code), signal strength value is 4 bytes, the last byte is fractional part.

③Redundancy check bits: 2 bytes (ASCII code), it is the accumulative sum of former 10 bytes(with decimal additions accumulated) as redundancy check code in transmission process.

For example: Master station Command 4, signal strength is 88.9, signal quality is 17.8, it should send 34, 30, 30, 38, 38, 39, 30, 31, 37, 38, 34, 35.

Note: accumulative sum is 45(should send 34, 35).

4.2.5.6 Answer Signal format for Master station Command 5

Command and symbol	redundancy check bits
①	②

①Command and symbol: 2 bytes, the first byte is Master station command 5; the second byte is insignificant (random 0 or 1).

②redundancy check bits: 2 bytes (ASCII code), it is the accumulative sum of former 2 bytes(with decimal additions accumulated) as redundancy check code in transmission process.

This command is used for clearing total flow of Slave station.

For example: Master station Command 5, it should send 35, 30, 36, 35.

Note: accumulative sum is 65(should send 36, 35).

4.2.5.7 Answer Signal format for Master station Command 6

Command and symbol	redundancy check bits
①	②

①Command and symbol: 2 bytes, the first byte is Master station command 6; the second byte is insignificant (random 0 or 1).

②Redundancy check bits: 2 bytes (ASCII code), it is the accumulative sum of former 2 bytes(with decimal additions accumulated) as redundancy check code in transmission process.

This command is used for clearing total working time of Slave station.

For example: Master station Command 6, it should send 36, 30, 36, 36.

Note: accumulative sum is 66(should send 36, 36).

5. KEY CODE

In a network environment, a key code is used to simulate the use of keys at the host device. For example, the instruction “M1” is input through the serial port, which is equivalent to pressing Key 1 on the keyboard of the CLAMP-ON 1100 ultrasonic flowmeter. Thus all functions of key operation can be completely implemented at the host device. All key

codes are shown in Table A-2.

Table A-2 Key Codes

key	Code of key(Hexadecimal system)	Code of key(Decimal system)	ASC II
0	30H	48	0
1	31H	49	1
2	32H	50	2
3	33H	51	3
4	34H	52	4
5	35H	53	5
6	36H	54	6
7	37H	55	7
8	38H	56	8
9	39H	57	9
.	3AH	58	:
<	3BH(0BH)	59	;
MENU	3CH(0CH)	60	<
ENT	3DH(0DH)	61	=
^ /+	3EH	62	>
v /-	3FH	63	?

APPENDIX 5 MODBUS-RTU COMMUNICATIONS PROTOCOL

CLAMP-ON 1100 series default Modbus output as Modbus-RTU protocol. The “D+” terminal is connected to RS485 “A”, and “D-” terminal is connected to RS485 “B”.

When use Modbus-RTU protocol, please refer to the following steps:

1. Connect output terminal “D+, D-” to RS485 “A, B”.
2. Enter Menu 50, select the output off.
3. Enter Menu 46, enter the meter address, and this address must be the same with modbus address. If users modify the meter address after power on meter, please restart meter.
4. Enter Menu 52, select RS232C.
5. Enter Menu 62, select RS232C 9600 None.
6. The corresponding Modbus address.

Address	Length	Function	RS232 Command
(40001)	0	Return Flow rate per day	DQD
(40003)	2	Return Flow rate per hour	DQH
(40005)	4	Return Flow rate per minute	DQM
(40007)	6	Return Flow rate per second	DQS
(40009)	8	Return Flow velocity	DV
(40011)	10	Return Positive totalizer	DI+
(40013)	12	Return Negative totalizer	DI-
(40015)	14	Return Net totalizer	DIN
(40017)	16	Return Positive Heat totalizer	DIE
(40019)	18	Return heat flow rate per second	E
(40021)	20	Return percentage of Analog Output	DS
(40023)	30	Return T1 value (0~20mA)	BA1
(40025)	32	Return T2 value (0~20mA)	BA2
(40027)	34	No used	BA3
(40029)	36	No used	BA4
(40031)	38	Return T1 input value	AI1
(40033)	40	Return T2 input value	AI2
(40035)	42	No used	AI3
(40037)	44	No used	AI4
(40039)	48	Return meter address	DID
(40041)	50	Return CLAMP-ON 1100 Electronic Serial Number (ESN)	ESN

Note: The data format of DI+, DI-, DIN, DIE, DID and ESN is long integer data format, high bit is before low bit, the highest bit is symbol bit. The other's data format is IEE754 floating-point data format, high bit is before low bit.



2FLOW AB

Address: KANSLIHUSVÄGEN 5, 28135 HÄSSLEHOLM, SWEDEN

Phone: +46 (0) 451 223 00

[Http://www.2flow.se](http://www.2flow.se)

